

# Model CBEX Elite 100-800 HP



## TABLE OF CONTENTS

FEATURES AND BENEFITS .....	3
PRODUCT OFFERING .....	3
DIMENSIONS AND RATINGS .....	4
PERFORMANCE DATA .....	10
ENGINEERING DATA .....	12
SAMPLE SPECIFICATIONS .....	21



## FEATURES AND BENEFITS

The CBEX Elite 100-800 HP Firetube boiler is designed, manufactured, and packaged by Cleaver-Brooks. All units are factory fire tested and shipped as a package, ready for quick connection to utilities. In addition to the features provided on all Cleaver-Brooks Firetube boilers, the following features apply to the CBEX.

### *Two Pass Design:*

- The packaged boiler offers high efficiency, flexibility, reliability, safety and ease of operation.

### *Front and Rear Access:*

- Provides access to front tube sheet and furnace.
- Large rear access plug for turnaround and furnace access.

### *Natural Gas, No. 2 Oil, or Combination Burners Available:*

- Combination gas/oil burners provide quick fuel changeover without burner adjustment.

## PRODUCT OFFERING

Burners are available to fire natural gas, No. 2 oil, or a combination of oil and gas. Standard product offering for 100-800 HP CBEX boilers is:

- Two pass wetback design.
- 150, 200, or 250 psig steam
- 30 and 125 psig hot water
- Full modulation, all sizes.

Available options include the following (contact your local Cleaver-Brooks authorized representative for option details).

- Boiler Options:
  - Additional screwed or flanged tappings.
  - Blowdown valves.
  - Non-return valves.
  - Feedwater valves and regulators.
  - Surface blowdown systems.
  - Surge load baffles.
  - Seismic design.
- Burner/Control Options:
  - Flame safeguard controllers.
  - Lead/lag system.
  - Special insurance and code requirements (e.g., IRI, FM, NFPA8501).
  - Alarm bell/silence switch.
  - Special motor requirements (TEFC, high efficiency).
  - Special indicating lights.
  - Main disconnect.
  - Elapsed time meter.

- NEMA enclosures.
- Remote emergency shut-off (115V).
- Circuit breakers.
- Day/night controls.
- Special power requirements.
- Low NOx Equipment.
- Fuel Options:
  - Gas strainer.
  - Gas pressure gauge.
  - Future gas conversion.
  - Oversized/undersized gas trains.
  - Optional Oil Pumps.

## ***DIMENSIONS AND RATINGS***

Dimensions and ratings are shown in the following tables and illustrations.

**NOTE:** The following information is subject to change without notice.

Table 1 - CBEX steam boiler ratings

Table 2 - CBEX hot water boiler ratings

Figure 1 / Table 3 - CBEX steam boiler dimensions

Figure 2 / Table 4 - CBEX hot water boiler dimensions

**Table 1. CBEX Steam Boiler Ratings**

BOILER H.P.	100	125	150	200	250	300	350	400	500	600	700	800
RATINGS - SEA LEVEL TO 700 FT.												
Rated Capacity (lbs-steam/hr from and at 212 °F)	3450	4313	5175	6900	8625	10350	12075	13800	17250	20700	24150	27600
Btu Output (1000 Btu/hr)	3347	4184	5021	6694	8368	10042	11715	13389	16736	20083	23430	26778
APPROXIMATE FUEL CONSUMPTION AT RATED CAPACITY BASED ON NOMINAL 82% EFFICIENCY												
Light Oil gph (140,000 Btu/gal)	29.2	36.4	43.7	58.3	72.9	87.5	102.0	116.6	145.8	174.9	204.1	233.3
Gas CFH (1000 Btu)	4082	5102	6123	8164	10205	12246	14287	16328	20410	24492	28574	32656
Gas (Therm/hr)	40.8	51.0	61.2	81.6	102.0	122.5	142.9	163.3	204.1	244.9	285.7	326.6
POWER REQUIREMENTS - SEA LEVEL TO 700 FT. (60 HZ)												
Blower Motor hp (60 ppm)A	2	7-1/2	7-1/2	10	10	20	15	15	15	25	40	50
Blower Motor hp (30 ppm)A	3	7-1/2	7-1/2	15	15	20	20	20	30	40	50	75
Blower Motor hp (9 ppm)A	3	7-1/2	7-1/2	15	15	20	20	25	30	50	75	n/a
Oil Pump Motor, No. 2 Oil	1/2	1/2	1/2	1/2	1/2	3/4	3/4	3/4	3/4	3/4	1	1
Air Compressor Motor hp (No. 2 Oil firing Only)	3	3	3	3	5	5	5	5	7-1/2	7-1/2	7-1/2	7-1/2
BOILER DATA												
Heating Surface sq-ft. (Fireside)	390	452	526	697	820	860	1122	1412	1642	1769	2230	2301
NOTES: A. Blower motor size for boiler operating pressures 125 psig and less, contact your local Cleaver-Brooks authorized representative for higher pressures and altitude.												

**Table 2. CBEX Hot Water Boiler Ratings**

BOILER H.P.	100	125	150	200	250	300	350	400	500	600	700	800
RATINGS - SEA LEVEL TO 700 FT.												
Btu Output (1000 Btu/hr)	3347	4184	5021	6694	8368	10042	11715	13389	16736	20083	23430	26778
APPROXIMATE FUEL CONSUMPTION AT RATED CAPACITY BASED ON NOMINAL 85% EFFICIENCY												
Light Oil gph (140,000 Btu/gal)	28.1	35.2	42.2	56.3	70.3	84.4	98.4	112.5	140.6	168.8	196.9	225.0
Gas CFH (1000 Btu)	3938	4922	5907	7876	9845	11814	13783	15752	19689	23627	27565	31503
Gas (Therm/hr)	39.4	49.2	59.1	78.8	98.4	118.1	137.8	157.5	196.9	236.3	275.7	315.0
POWER REQUIREMENTS - SEA LEVEL TO 700 FT. (60 HZ)												
Blower Motor hp (60 ppm)	2	7-1/2	7-1/2	10	10	20	15	15	15	25	40	50
Blower Motor hp (30 ppm)	3	7-1/2	7-1/2	15	15	20	20	20	30	40	50	75
Blower Motor hp (9 ppm)	3	7-1/2	7-1/2	15	15	20	20	25	30	50	75	n/a
Oil Pump Motor, No. 2 Oil	1/2	1/2	1/2	1/2	1/2	3/4	3/4	3/4	3/4	3/4	1	1
Air Compressor Motor hp (No. 2 Oil firing Only)	3	3	3	3	5	5	5	5	7-1/2	7-1/2	7-1/2	7-1/2
BOILER DATA												
Heating Surface sq-ft. (Fireside)	390	452	526	697	820	860	1122	1412	1642	1769	2230	2301

Figure 1. CBEX Elite Steam Boiler Dimensions, 100-800 HP

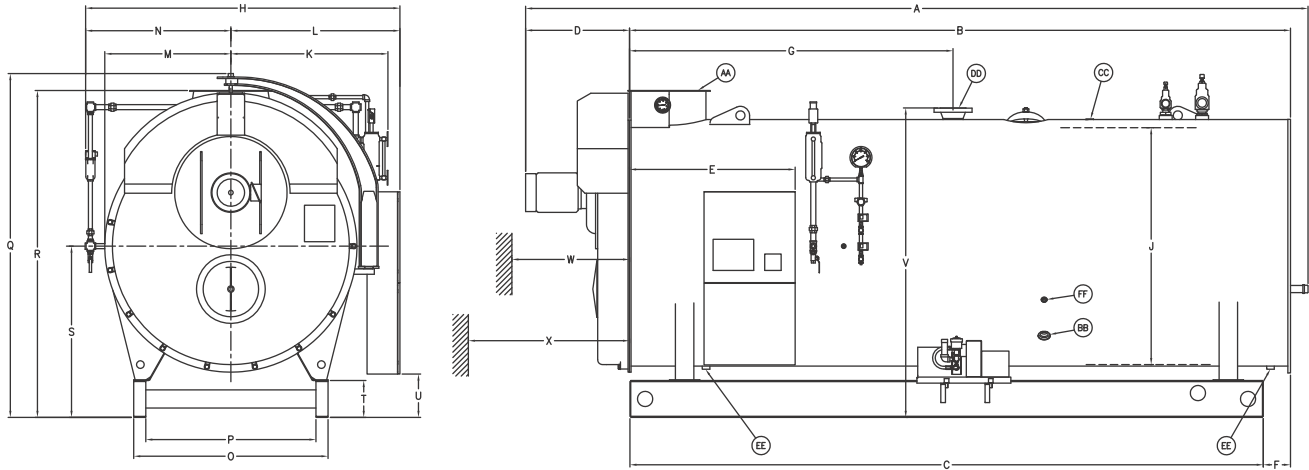

100 THRU 200 HP BOILERS USE A FRONT DOOR HINGE (NOT DAVIT AS SHOWN)

Table 3. CBEX Elite Steam Boiler Dimensions 100-800 HP

BOILER H.P.	DIM	100	125	150	200	250	300	350	400	500	600	700	800
<b>LENGTHS</b>													
Overall Length (60 PPM system)	A	165	172	176.5	201.5	231.5	242.5	249	265	260.5	282.5	291	299
Overall Length (30 PPM system)	A	167	176	180.5	203.5	233.5	243.5	255	268	271.5	287.5	298	307
Overall Length (9 PPM system)	A	167	176	182.5	205.5	233.5	243.5	255	270	271.5	288.5	300	n/a
Shell	B	137.5	144.5	149	168	196	204	217.5	226.5	229	244	253	260
Base Frame	C	130.5	137.5	140	159	186	194	208.5	217.5	219.5	234.5	243.5	250.5
Front Head Extension (60 PPM system)	D	21.5	21.5	21.5	27.5	29.5	32.5	25.5	32.5	25.5	32.5	32	33
Front Head Extension (30 PPM system)	D	23.5	25.5	25.5	29.5	31.5	33.5	31.5	35.5	36.5	37.5	39	41
Front Head Extension (9 PPM system)	D	23.5	25.5	27.5	31.5	31.5	33.5	31.5	37.5	36.5	38.5	41	n/a
Front Ring Flange to Panel	E	46	46	48	48	47	47	57	57	52	52	52	52
Rear Ring Flange to Base	F	7	7	9	9	10	10	9	9	9.5	9.5	9.5	9.5
Shell Flange to Steam Nozzle	G	62.5	66	73.5	75.5	96.5	100.5	106.5	111	114.5	122	126.5	130
<b>WIDTHS</b>													
Overall Width	H	81	81	86	86	94	94	105	105	112	112	119	119
I.D. Boiler	J	55	55	60	60	67	67	78	78	85	85	92	92
Center to Water Column	K	42.5	42.5	45	45	48.5	48.5	54	54	57.5	57.5	61	61
Center to Panel	L	44.5	44.5	47	47	50.5	50.5	56	56	59.5	59.5	63	63
Center to Lagging	M	30.5	30.5	33	33	36.5	36.5	42	42	45.5	45.5	49	49
Center to Auxiliary LWCO	N	36.5	36.5	39	39	43.5	43.5	49	49	52.5	52.5	56	56
Base Outside	O	47.5	47.5	52.5	52.5	51	51	64	64	60	60	68	68
Base Inside	P	39.5	39.5	44.5	44.5	43	43	56	56	47	47	55	55
<b>HEIGHTS</b>													
Overall Height	Q	81.5	81.5	87	87	101.5	101.5	113	113	122	122	130	130
Base to Vent Outlet	R	81	81	87	87	94.5	94.5	108	108	114.5	114.5	122.5	122.5
Base to Boiler Centerline	S	41	41	46	46	50	50	56.5	56.5	61	61	65.5	65.5
Height of Base Frame	T	12	12	12	12	12	12	12	12	12	12	12	12
Base to Bottom of Panel	U	17	17	17	17	20	20	24	24	23	23	23	23
Base to Steam Outlet	V	78.5	78.5	82.5	82.5	90	90	102	102	110	110	118	118

**Table 3. CBEX Elite Steam Boiler Dimensions 100-800 HP (Continued)**

BOILER H.P.	DIM	100	125	150	200	250	300	350	400	500	600	700	800
<b>BOILER CONNECTIONS</b>													
Feedwater Inlet (Both Sides)	BB	1.25	1.5	1.5	2	2	2	2.5	2.5	2.5	2.5	2.5	2.5
Surface Blowoff	CC	1	1	1	1	1	1	1	1	1	1	1	1
Steam Nozzle (300# ANSI Flange)	DD	4	4	4	4	6	6	6	6	8	8	8	8
Blowdown-Front & Rear	EE	1.25	1.5	1.5	1.5	1.5	1.5	1.5	2	2	2	2	2
Chemical Feed	FF	1	1	1	1	1	1	1	1	1	1	1	1
<b>VENT STACK</b>													
Vent Stack Diameter (Flanged)	AA	16	16	16	16	20	20	24	24	24	24	24	24
<b>MINIMUM CLEARANCES</b>													
Front Door Swing	W	62	62	67	67	78	78	89	89	97	97	104	104
Tube Removal - Front Only	X	89	96	101	120	142	142	160	169	172	187	196	203
<b>MINIMUM BOILER ROOM LENGTH ALLOWING FOR DOOR SWING AND TUBE REMOVAL:</b>													
Thru Window or Door		205.5	212.5	222	241	280	288	312.5	321.5	332	347	363	370
Front of Boiler		232.5	246.5	256	294	344	352	383.5	401.5	407	437	455	469
<b>WEIGHTS IN LBS</b>													
Normal Water Weight		6,550	6,890	8,010	9,060	11,620	12,190	19,340	19,650	20,060	21,620	25,050	25,870
Approx. Shipping Weight - (150psig)		10,650	11,180	12,520	13,900	17,960	18,540	25,960	26,780	31,580	33,320	39,830	40,840

**NOTES:**

Accompanying dimensions, while sufficiently accurate for layout purposes, must be confirmed for construction by certified dimension diagram/drawing. All connections are threaded unless otherwise indicated.

Figure 2. CBEX Elite Hot Water Boiler Dimensions, 100-800 HP

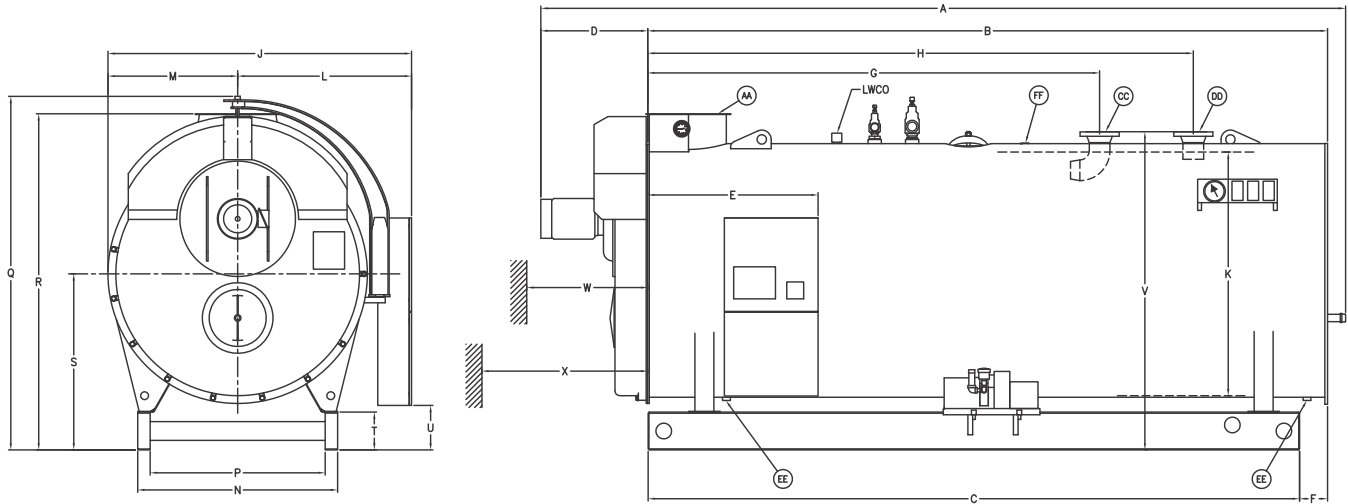

100 THRU 200 HP BOILERS USE A FRONT DOOR HINGE (NOT DAVIT AS SHOWN)

Table 4. CBEX Elite Hot Water Boiler Dimensions 100-800 HP

BOILER H.P.	DIM	100	125	150	200	250	300	350	400	500	600	700	800
<b>LENGTHS</b>													
Overall Length (60 PPM system)	A	165	172	176.5	201.5	231.5	242.5	249	265	260.5	282.5	291	299
Overall Length (30 PPM system)	A	167	176	180.5	203.5	233.5	243.5	255	268	271.5	287.5	298	307
Overall Length (9 PPM system)	A	167	176	182.5	205.5	233.5	243.5	255	270	271.5	288.5	300	n/a
Shell	B	137.5	144.5	149	168	196	204	217.5	226.5	229	244	253	260
Base Frame	C	130.5	137.5	140	159	186	194	208.5	217.5	219.5	234.5	243.5	250.5
Front Head Extension (60 PPM system)	D	21.5	21.5	21.5	27.5	29.5	32.5	25.5	32.5	25.5	32.5	32	33
Front Head Extension (30 PPM system)	D	23.5	25.5	25.5	29.5	31.5	33.5	31.5	35.5	36.5	37.5	39	41
Front Head Extension (9 PPM system)	D	23.5	25.5	27.5	31.5	31.5	33.5	31.5	37.5	36.5	38.5	41	n/a
Front Ring Flange to Panel	E	46	46	48	48	47	47	57	57	52	52	52	52
Rear Ring Flange to Base	F	7	7	9	9	10	10	9	9	9.5	9.5	9.5	9.5
Shell Flange to Water Return	G	84	89	96	108	134	139	148	155	156	166	173	177
Shell Flange to Water Outlet	H	109	114	121	133	160	165	174	181	192	202	209	213
<b>WIDTHS</b>													
Overall Width	J	75	75	80	80	87	87	98	98	105	105	112	112
I.D. Boiler	K	55	55	60	60	67	67	78	78	85	85	92	92
Center to Panel	L	44.5	44.5	47	47	50.5	50.5	56	56	59.5	59.5	63	63
Center to Lagging	M	30.5	30.5	33	33	36.5	36.5	42	42	45.5	45.5	49	49
Base Outside	O	47.5	47.5	52.5	52.5	51	51	64	64	60	60	68	68
Base Inside	P	39.5	39.5	44.5	44.5	43	43	56	56	47	47	55	55
<b>HEIGHTS</b>													
Overall Height	Q	81.5	81.5	87	87	101.5	101.5	113	113	122	122	130	130
Base to Vent Outlet	R	81	81	87	87	94.5	94.5	108	108	114.5	114.5	122.5	122.5
Base to Boiler Centerline	S	41	41	46	46	50	50	56.5	56.5	61	61	65.5	65.5
Height of Base Frame	T	12	12	12	12	12	12	12	12	12	12	12	12
Base to Bottom of Panel	U	17	17	17	17	20	20	24	24	23	23	23	23
Base to Water Return & Outlet	V	78.5	78.5	82.5	82.5	90	90	102	102	110	110	118	118

**Table 4. CBEX Elite Hot Water Boiler Dimensions 100-800 HP (Continued)**

BOILER H.P.	DIM	100	125	150	200	250	300	350	400	500	600	700	800
<b>BOILER CONNECTIONS</b>													
Water Return (150# ANSI Flange)	CC	4	6	6	6	8	8	8	10	10	12	12	12
Water Out (150# ANSI Flange w/Dip Tube)	DD	4	6	6	6	8	8	8	10	10	12	12	12
Drain-Front & Rear	EE	1.5	1.5	1.5	2	2	2	2	2	2	2	2	2
Air Vent	FF	1.5	1.5	1.5	1.5	1.5	1.5	1.5	2	2	2	2	2
<b>VENT STACK</b>													
Vent Stack Diameter (Flanged)	AA	16	16	16	16	20	20	24	24	24	24	24	24
<b>MINIMUM CLEARANCES</b>													
Front Door Swing	W	62	62	67	67	78	78	89	89	97	97	104	104
Tube Removal - Front Only	X	89	96	101	120	142	142	160	169	172	187	196	203
<b>MINIMUM BOILER ROOM LENGTH ALLOWING FOR DOOR SWING AND TUBE REMOVAL:</b>													
Thru Window or Door		205.5	212.5	222	241	280	288	312.5	321.5	332	347	363	370
Front of Boiler		232.5	246.5	256	294	344	352	383.5	401.5	407	437	455	469
<b>WEIGHTS IN LBS</b>													
Normal Water Weight		7,270	7,640	9,200	10,400	14,300	14,970	22,950	23,400	25,950	27,880	33,000	34,000
Approx. Shipping Weight - (30 psig)		9,040	9,510	10,630	11,950	14,900	15,670	20,100	21,420	25,100	26,400	31,350	32,130
Approx. Shipping Weight - (125 psig)		9,470	10,100	11,380	12,970	16,430	17,240	23,000	23,320	29,100	30,500	38,050	39,000

**PERFORMANCE DATA**

**Efficiency**

Tables 5 and 6 show predicted fuel-to-steam efficiencies (including radiation and convection losses) for Cleaver-Brooks CBEX firetube boilers. For specific efficiencies on firetube boiler offerings not listed here, contact your local Cleaver-Brooks authorized representative.

Cleaver-Brooks offers an industry leading fuel-to-steam boiler efficiency guarantee for CBEX Firetube Boilers. The guarantee is based on the fuel-to-steam efficiencies shown in the efficiency tables and the following conditions. The efficiency percent number is only meaningful if the specific conditions of the efficiency calculations are clearly stated in the specification (see Cleaver-Brooks publication CB-7767 for a detailed description of efficiency calculations).

The boiler manufacturer shall guarantee that, at the time of startup, the boiler will achieve fuel-to-steam efficiency (as shown in the tables listed above) at 100% firing rate (add efficiency guarantees at 25%, 50%, and 75% of rating, if required). If the boiler(s) fail to achieve the corresponding guaranteed efficiency as published, the boiler manufacturer will rebate, to the ultimate boiler owner, five thousand dollars (\$5,000) for every full efficiency point (1.0%) that the actual efficiency is below the guaranteed level. The specified boiler efficiency is based on the following conditions.

1. Fuel specification used to determine boiler efficiency:

• Natural Gas	• No. 2 Oil
Carbon,% (wt) = 69.98	Carbon,% (wt) = 85.8
Hydrogen,% (wt) = 22.31	Hydrogen,% (wt) = 12.7
Sulfur,% (wt) = 0.0	Sulfur,% (wt) = 0.2
Heating value, Btu/lb = 21,830	Heating value, Btu/lb = 19,420

2. Efficiencies are based on ambient air temperature of 80 °F, relative humidity of 30%, and 15% excess air in the exhaust flue gas.
3. Efficiencies are based on the following radiation and convection losses. Firing rate of 25% - 1.2%, 50% - 0.6%, 75% - 0.4%, and 100% - 0.3%.

**Table 5. CBEX Fuel-to-Steam Efficiencies Natural Gas (with heat recovery)**

**Table 6. CBEX Fuel-to-Steam Efficiencies #2 Oil (with heat recovery)**

BHP	OPERATING PRESSURE = 125 psig			
	% OF LOAD			
	25%	50%	75%	100%
100	85.2	85.1	84.6	84.1
125	85.0	85.0	84.8	84.4
150	84.9	84.9	84.7	84.3
200	84.4	84.6	84.5	84.3
250	85.2	85.1	84.6	84.1
300	85.0	84.9	84.5	84.0
350	85.0	85.0	84.7	84.3
400	85.5	85.3	85.0	84.5
500	85.3	85.1	84.8	84.4
600	85.2	85.1	84.8	84.5
700	85.2	85.1	84.9	84.6
800	85.1	85.1	84.8	84.6

BHP	OPERATING PRESSURE = 125 psig			
	% OF LOAD			
	25%	50%	75%	100%
100	88.0	87.9	87.5	86.9
125	87.8	87.9	87.6	87.2
150	87.7	87.8	87.5	87.1
200	87.2	87.4	87.3	87.1
250	88.0	87.9	87.4	86.9
300	87.8	87.7	87.3	86.8
350	87.8	87.8	87.5	87.1
400	88.3	88.2	87.8	87.3
500	88.1	87.9	87.6	87.2
600	88.0	87.9	87.6	87.3
700	88.0	87.9	87.7	87.4
800	88.0	87.9	87.7	87.4

Emissions

**Table 6. CBEX Natural Gas Estimated Emission Levels**

POLLUTANT	UNITS	60 PPM SYSTEM	30 PPM SYSTEM	9 PPM SYSTEM	7 PPM SYSTEM
CO	ppm <sup>A</sup>	10	10	25	50
	lb/MMBtu	0.0075	0.0075	0.018	0.037
NOx	ppm <sup>A</sup>	60	30	9	7
	lb/MMBtu	0.07	0.035	0.0105	0.0082
SOx	ppm <sup>A</sup>	1	1	1	1
	lb/MMBtu	0.001	0.001	0.001	0.001
HC/VOC5	ppm <sup>A</sup>	8	8	4	4
	lb/MMBtu	0.0032	0.0032	0.0016	0.0016
PM	ppm <sup>A</sup>	-	-	-	-
	lb/MMBtu	0.01	0.01	0.01	0.01

A. ppm levels are given on a dry volume basis and corrected to 3% oxygen (15% excess air)

**Table 7. CBEX #2 Oil Estimated Emission Levels**

POLLUTANT	UNITS	60 PPM SYSTEM	30 PPM SYSTEM	9 PPM SYSTEM	7 PPM SYSTEM
CO	ppm <sup>A</sup>	10	10	10	10
	lb/MMBtu	0.008	0.008	0.008	0.008
NOx	ppm <sup>A</sup>	120	90	70	70
	lb/MMBtu	0.16	0.12	0.093	0.093
SOx	ppm <sup>A</sup>	55	55	55	55
	lb/MMBtu	0.1	0.1	0.1	0.1
HC/VOC5	ppm <sup>A</sup>	4	4	4	4
	lb/MMBtu	0.002	0.002	0.002	0.002
PM	ppm <sup>A</sup>	-	-	-	-
	lb/MMBtu	0.025	0.025	0.025	0.025

A. ppm levels are given on a dry volume basis and corrected to 3% oxygen (15% excess air)  
 BASED ON THE FOLLOWING CONSTITUENT LEVELS:  
 Fuel-bound Nitrogen content = 0.015% or less by weight.  
 Sulfur content = 0.1% by weight.  
 Ash content = 0.01% by weight.

**ENGINEERING DATA**

The following engineering information is provided for CBEX Boilers. Additional detail is available from your local Cleaver-Brooks authorized representative.

**Boiler Information**

Tables 9 and 10 list quantity and outlet size for safety/relief valves supplied on CBEX boilers.

Table 11 shows steam volume and disengaging area.

Table 12 gives recommended steam nozzle sizes.

Table 13 shows recommended non-return valve sizes.

**Table 8. Safety valves steam**

VALVE SETTING	150 PSIG STEAM		200 PSIG STEAM		250 PSIG STEAM	
	NO. OF VALVES REQ'D	OUTLET SIZE	NO. OF VALVES REQ'D	OUTLET SIZE	NO. OF VALVES REQ'D	OUTLET SIZE
100	1	1-1/2"	1	1-1/2"	1	1-1/4"
125	2	1-1/4"	2	(1) 1-1/4" (1) 1"	2	1"
150	2	(1) 1-1/2" (1) 1-1/4"	2	(1) 1-1/4" (1) 1"	2	1"
200	2	1-1/2"	2	(1) 1-1/2" (1) 1-1/4"	2	1-1/4"
250	2	(1) 2" (1) 1-1/2"	2	(1) 1-1/2" (1) 1-1/4"	2	(1) 1-1/2" (1) 1-1/4"
300	2	(1) 2" (1) 1-1/2"	2	1-1/2"	2	(1) 1-1/2" (1) 1-1/4"
350	2	2"	2	(1) 2" (1) 1-1/2"	2	1-1/2"
400	2	(1) 2-1/2" (1) 2"	2	(1) 2" (1) 1-1/2"	2	(1) 2" (1) 1-1/2"
500	2	(1) 2-1/2" (1) 2"	2	(1) 2-1/2" (1) 2"	2	(1) 2" (1) 1-1/2"
600	2	2-1/2"	2	(1) 2-1/2" (1) 2"	2	2"
700, 800	3	(2) 2-1/2" (1) 2"	2	2-1/2"	2	(1) 2-1/2" (1) 2"

NOTE: Valve manufacturers are Kunkle, Consolidated or Conbraco, depending on availability.

**Table 9. Relief valves hot water**

VALVE SETTING	30 PSIG HW		125 PSIG HW	
	NO. OF VALVES REQ'D	OUTLET SIZE	NO. OF VALVES REQ'D	OUTLET SIZE
100	1	2-1/2"	1	1-1/4"
125	1	2-1/2"	1	1-1/4"
150	1	2-1/2"	1	2"
200	2	(1) 2-1/2" (1) 1-1/4"	1	2"
250	2	(1) 2" (1) 2-1/2"	1	2"
300	2	2-1/2"	1	2-1/2"
350	3	(2) 2-1/2" (1) 1"	1	2-1/2"
400	3	(1) 2" (2) 2-1/2"	1	2-1/2"
500	4	(1) 1" (3) 2-1/2"	2	(1) 1" (1) 2-1/2"
600	4	(3) 2-1/2" (1) 2"	2	(1) 1-1/4" (1) 2-1/2"
700, 800	5	(1) 1" (4) 2-1/2"	2	(1) 2-1/2" (1) 2"

NOTE: Relief valve is Kunkle #537 for 30# & 125#(Section IV) boiler and is Kunkle #927 for 150# HTHW(Section I) boiler.

**Table 10. CBEX Elite steam volume and disengaging area**

BOILER HP	STEAM VOLUME CU-FT	STEAM RELIEVING AREA SQ-IN
100	10.2	4291
125	10.7	4522
150	17.6	5544
200	20.1	6322
250	34.3	8597
300	35.8	8971
350	50.7	11059
400	53.0	11563
500	78.9	13550
600	84.5	14515
700	107.2	16517
800	110.3	17006

NOTE:

Based on normal water level.

Based on 150 psig design pressure.

**Table 11. CBEX Elite recommended steam nozzle size**

OPERATING PRESSURE PSIG	BOILER HP											
	100	125	150	200	250	300	350	400	500	600	700	800
50	4	6	6	6	6	8	8	8	8	10	10	12
75	4	4	4	6	6	6	8	8	8	8	10	10
100	4	4	4	6	6	6	6	6	8	8	8	10
125	4	4	4	4	6	6	6	6	8	8	8	8
150	2.5	3	3	4	4	6	6	6	6	6	8	8
200	2.5	2.5	3	4	4	4	4	6	6	6	6	6
250	2	2.5	2.5	3	4	4	4	4	6	6	6	6

NOTES:

1. Steam nozzle sizes given in inches.
2. Recommended steam nozzle sizes based on 4000 to 5000 fpm steam velocity.

**Table 12. CBEX Elite recommended Non-Return Valve size**

BOILER HP	BOILER CAPACITY (LBS/HR)	OPERATING PRESSURE (PSIG)							
		50	75	100	125	150	175	200	250
100	3450	3	2-1/2	2-1/2	2-1/2	2-1/2	2-1/2	2-1/2	2-1/2
125	4313	4	3	3	3	3	2-1/2	2-1/2	2-1/2
150	5175	4	4	3	3	3	3	2-1/2	2-1/2
200	6900	4	4	4	3	3	3	3	3
250	8625	4	4	4	4	3	3	3	3
300	10350	6	4	4	4	4	4	4	3
350	12025	6	6	4	4	4	4	4	3
400	13800	6	6	4	4	4	4	4	4
500	17210	6	6	6	6	4	4	4	4
600	20700	8	8	6	6	6	4	4	4
700	24150	8	8	6	6	6	6	6	6
800	27600	8	8	6	6	6	6	6	6

NOTE: Valve sizes (300 psig flanges) given in inches.

**Blowdown Water Requirements**

Some local codes require blowdown tanks to be constructed in accordance with recommendations of the National Board of Boiler and Pressure Vessel Inspectors.

The National Board’s recommendations base the size of the blowdown tank on the removal of at least 4 inches of water from the boiler.

Table 14 lists the approximate quantity of water represented by 4 inches of water at normal operating level for Cleaver-Brooks CBEX Boilers.

**Table 13: Blowdown tank sizing**

BOILER HP	WATER (GAL)
100	84
125	89
150	106
200	120
250	161
300	167
350	205
400	214
500	247
600	264
700	300
800	309

NOTE: Quantity of water removed from boiler by lowering normal water line 4".

## Burner Characteristics

Note that altitude correction and burner changes are required for higher altitudes which may alter dimensions, motor hp and gas pressures. Also 50 Hz applications and low NOx options should be reviewed by the Cleaver-Brooks authorized representative.

### *Fuel Connections - Gas*

The local gas company should be consulted for requirements and authorization for installation and inspection of gas supply piping. Installation of gas supply piping and venting must be in accordance with all applicable engineering guidelines and regulatory codes. All connections made to the boiler should be arranged so that all components remain accessible for inspection, cleaning and maintenance.

A drip leg should be installed in the supply piping before the connection to the gas pressure regulator. The drip leg should be at least as large as the inlet fitting supplied with the boiler. Consideration must be given to both volume and pressure requirements when choosing gas supply piping size. Refer to the boiler dimension diagram provided by Cleaver-Brooks for the particular installation. Connections to the burner gas train should be made with a union, so that gas train components or the burner may be easily disconnected for inspection or service. Upon completion of the gas piping installation, the system should be checked for gas leakage and tight shutoff of all valves.

### *Fuel Connections - Oil*

Oil-fired burners are equipped with an oil pump, which draws fuel from a storage tank and supplies pressurized oil to the burner nozzle(s). The burner supply oil pump has a greater capacity than the burner requires for the maximum firing rate. Fuel not delivered to the nozzle is returned to the storage tank. A two-pipe (supply and return) oil system is recommended for all installations. Oil lines must be sized for the burner and burner supply oil pump capacities.

The burner supply oil pump suction should not exceed 10" Hg. If a transfer pump is used, it must have a pumping capacity at least equal to that of the burner pump(s). Supply pressure to the burner pump should not exceed 3 psig.

A strainer must be installed in the supply piping upstream of the burner supply pump in order to prevent entry of foreign material into the pump, fuel control valves, or burner nozzle(s). The strainer must be sized for the burner supply pump capacity. A strainer mesh of 150 microns (0.005") is recommended.

Install a check valve in the line to prevent draining of the oil suction line when the burner is not in operation. Location of the check valve varies with the system, but usually it is located as close as possible to the storage tank.

Installation of a vacuum gauge in the burner supply line between the burner oil pump and the strainer is recommended. Regular observation and recording of the gauge indication will assist in determining when the strainer needs servicing.

Upon completion of the oil piping installation, the system should be checked for oil or air leakage and tight shutoff of all valves.

*Gas pressure requirements*

**Table 14. Model CBEX Elite, Minimum Required Gas Pressure at Entrance to C-B Supplied Regulator/Gas Valve**

BOILER HP	Combination Regulator and Gas Valve Size (in)	PRESSURE REQUIRED ("WC)
100	1.5	12.5
125	1.5	20
150	1.5	27.5
200	1.5	38.5
250	2	41
300	2	55
350	2	75.5
400	2	92
500	2.5	55
600	2.5	79
700	3	80.5
800	3	105

Note: For undersized or oversized gas trains or altitudes above 700 feet, contact your local Cleaver-Brooks representative.

**Table 15. CBEX altitude correction for gas**

ALTITUDE (FT)	CORRECTION FACTOR	ALTITUDE (FT)	CORRECTION FACTOR
1000	1.04	6000	1.25
2000	1.07	7000	1.3
3000	1.11	8000	1.35
4000	1.16	9000	1.4
5000	1.21	-	-

To obtain minimum required gas pressure at altitudes above 700 feet, multiply the pressure by the listed factors:

Inches WC x 0.577 = oz/sq-in.

oz/sq-in x 1.732 = inches WC.

Inches WC x 0.0361 = psig.

oz/sq-in x 0.0625 = psig.

psig x 27.71 = Inches WC.

psig x 16.0 = oz/sq-in.

**Boiler Room Information**

Table 17 shows typical boiler room width requirements.

**Table 16. Boiler room width**

BOILER HP	100-125	150-200	250-300	350-400	500-600	700-800
DIM. "A"	86	88	92	98	102	105
DIM. "B"	120	127	144	151	174	178

**NOTES:**

1. Recommended Minimum Distance Between Boiler and Wall. Dimension "A" allows for a clear 42" aisle between the water column on the boiler and the wall. If space permits, this aisle should be widened.
2. Recommended Minimum Distance Between Boilers. Dimension "B" between boilers allows for a "clear" aisle of:
  - 42" - 100-200 HP
  - 48" - 250-400 HP
  - 60" - 500-800 HP
 If space permits, this aisle should be widened.

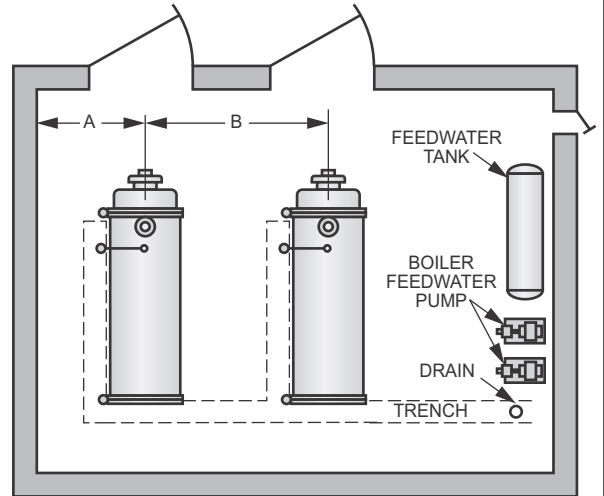

**Stack Support Capabilities**

CBEX boilers can support up to 2000 lbs. without additional support.

CBEX boilers can be reinforced to support up to 3000 lbs.

**Boiler Room Combustion Air**

When determining boiler room air requirements, the size of the room, air flow, and velocity of air must be reviewed as follows:

1. Size (area) and location of air supply openings in boiler room.
  - A. Two (2) permanent air supply openings in the outer walls of the boiler room are recommended. Locate one (1) at each end of the boiler room, preferably below a height of 7 feet. This allows air to sweep the length of the boiler.
  - B. Air supply openings can be louvered for weather protection, but they should not be covered with fine mesh wire, as this type of covering has poor air flow qualities and is subject to clogging by dust or dirt.
  - C. A vent fan in the boiler room is not recommended, as it could create a slight vacuum under certain conditions and cause variations in the quantity of combustion air. This can result in unsatisfactory burner performance.
  - D. Under no condition should the total area of the air supply openings be less than one (1) square foot.
  - E. Size the openings by using the formula:

$$\text{Area (sq-ft)} = \text{CFM/FPM}$$

2. Amount of air required (cfm).
  - A. Combustion Air = Rated bhp x 8 cfm/bhp.
  - B. Ventilation Air = Maximum bhp x 2 cfm/bhp or a total of 10 cfm/bhp - up to 1000 feet elevation. Add 3 percent more per 1000 feet of added elevation.
3. Acceptable air velocity in Boiler Room (fpm).
  - A. From floor to (7) foot height - 250 fpm.
  - B. Above (7) foot height - 500 fpm.

Example: Determine the area of the boiler room air supply openings for (1) 1000 hp boiler at 800 feet altitude.

The air openings are to be 5 feet above floor level.

- Air required:  $1000 \times 10 = 10000$  cfm (from 2B above).
- Air velocity: Up to 7 feet = 250 fpm (from 3 above).
- Area Required:  $\text{Area} = \text{cfm}/\text{fpm} = 10000/250 = 40$  Sq-ft total.
- Area/Opening:  $40/2 = 20$  sq-ft/opening (2 required).

**Notice**

*Consult local codes, which may supersede these requirements.*

**Stack/Breeching Size Criteria**

The design of the stack and breeching must provide the required draft at each boiler flue gas outlet. Proper draft is critical to burner performance.

Although constant pressure at the flue gas outlet of the CBEX is not required, it is necessary to size the stack/breeching to limit flue gas pressure variation. The allowable pressure range is  $-0.50''$  W.C. to  $+0.50''$  W.C. The maximum pressure variation at any firing rate for the boiler is  $0.50''$  W.C.

The low NOx option allowable pressure range is  $-0.25''$  W.C. to  $+0.25''$  W.C. The maximum pressure variation at any firing rate for the boiler is  $0.25''$  W.C.

Stack and breeching sizes should always be provided by a reputable stack supplier who will design the stack and breeching system based on the above criteria. Your local Cleaver-Brooks authorized representative is capable of assisting in your evaluation of the stack/breeching design.

**Table 17. CBEX lifting lugs**

BOILER HP	ALL DIMENSIONS IN INCHES				
	A	B	C	D	E
100	75.25	21.375	101.75	10	3
125	75.25	21.375	108.75	10	3
150	79.5	21.375	102.5	10	3
200	79.5	21.375	121.5	10	3
250	87.25	27.5	131.25	10	3
300	87.25	27.5	139.25	10	3
350	99.5	36.375	144	10	3
400	99.5	36.375	153	10	3
500	107.625	36.5	162	10	3
600	107.625	36.5	177	10	3
700	115.75	37.75	183.5	10	3
800	115.75	37.75	190.5	10	3

NOTE: Dimensions A, B, and C may vary by 1 inch.

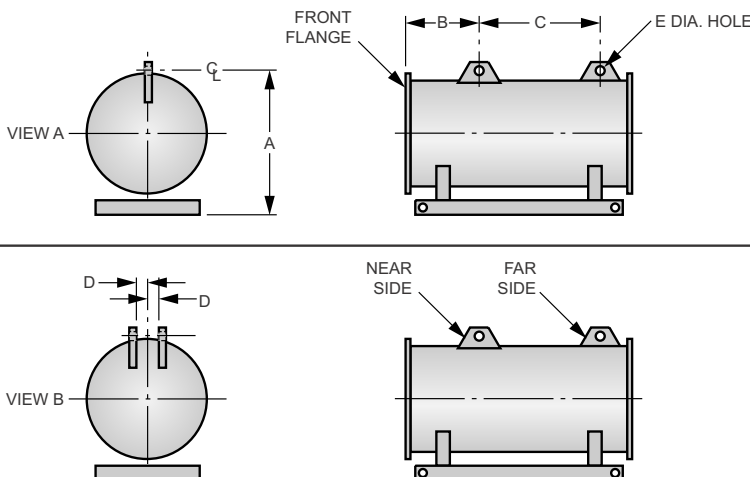
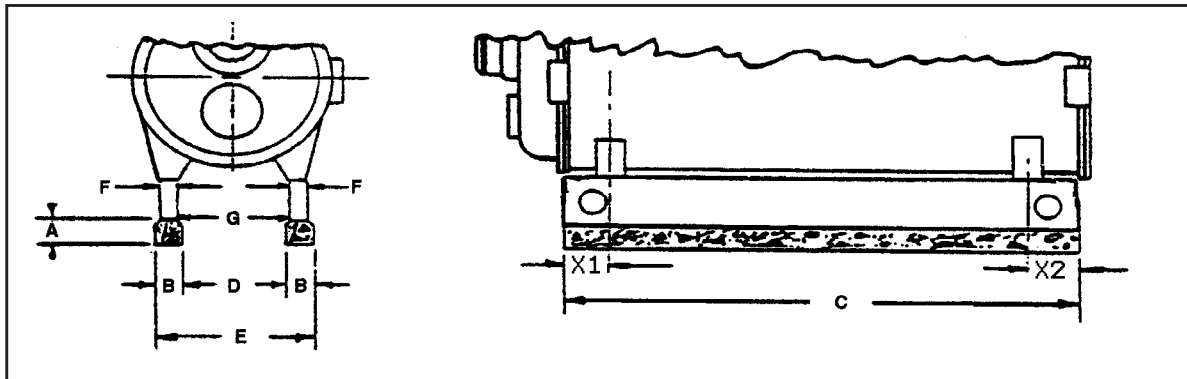

**Table 18. CBEX Elite boiler mounting piers**

BOILER HP	ALL DIMENSIONS IN INCHES								
	A	B	C	D	E	F	G	X1	X2
100	6	9	130.5	34.5	52.5	4	39.5	15	11.5
125	6	9	137.5	34.5	52.5	4	39.5	15	11.5
150	6	9	140	39.5	57.5	4	44.5	13	11.5
200	6	9	159	39.5	57.5	4	44.5	13	11.5
250	6	9	186.125	38	56	4	43	16	8
300	6	9	194.125	38	56	4	43	16	8
350	6	12	208.5	48	72	4	56	18	11.5
400	6	12	217.5	48	72	4	56	18	11.5
500	6	12	219.5	41.5	65.5	6.5	47	16	11.5
600	6	12	234.5	41.5	65.5	6.5	47	16	11.5
700	6	12	243.5	49.5	73.5	6.5	55	15	12.5
800	6	12	250.5	49.5	73.5	6.5	55	15	12.5

**NOTE:**

6-inch high mounting piers recommended for use beneath the boiler base frame. The use of these piers provides increased inspection accessibility to the boiler and added height for washing down the area beneath the boiler.





## Sample Specifications Steam

### Model CBEX Elite 100-800 HP

GENERAL	
Boiler Characteristics (Steam) -----	22
PRODUCTS	
General Boiler Design -----	22
Steam Boiler Trim -----	23
Burner -----	23
Fuel Specification And Piping -----	24
60 PPM-----	24
30 PPM-----	29
9 PPM -----	35
7 PPM -----	41
Boiler Controls And Control Panel -----	47
Flue Gas Heat Recovery (Optional Selection) -----	47
Efficiency Guarantee -----	47
EXECUTION	
Warranty -----	47
Shop Tests -----	47

### **SAMPLE SPECIFICATIONS**

The following sample specifications are provided by Cleaver-Brooks to assist you in meeting your customer's specific needs and application.

The Sample Specifications are typically utilized as the base template for the complete boiler specification. Contact your local Cleaver-Brooks authorized representative for information on special insurance requirements, special code requirements, optional equipment, or general assistance in completing the specification.

**PART 1 GENERAL**  
**CBEX Steam Boiler 100-800 HP**

1.1 BOILER CHARACTERISTICS (STEAM)

- A. The Steam Boiler shall be Cleaver-Brooks Fuel Series \_\_\_\_\_ (100, 200, 700), \_\_\_\_\_ hp designed for \_\_\_\_\_ psig (150, 200, or 250 psig steam). The maximum operating pressure shall be \_\_\_\_\_ psig and the minimum operating pressure shall be \_\_\_\_\_ psig (note - minimum allowable operating pressure on the CBEX is 50 psig).
- B. The boiler shall have a maximum output of \_\_\_\_\_ Btu/hr, or \_\_\_\_\_ horsepower when fired with CS12-48 #2 oil and/or natural gas, \_\_\_\_\_ Btu/cu-ft. Electrical power available shall be \_\_\_\_\_ Volt \_\_\_\_\_ Phase \_\_\_\_\_ Cycle.

**PART 2 PRODUCTS**

2.1 GENERAL BOILER DESIGN

- A. Design shall be optimized using CFD modeling verifiable by manufacturer. The boiler shall be a multipass horizontal firetube updraft boiler with using extended heating surface optimized to reduce boiler foot print. Boiler shall be mounted on a heavy steel frame with integral forced draft burner and burner controls.
1. The boiler shall be completely preassembled and fire tested at the factory. The unit shall be ready for immediate mounting on floor or simple foundation and ready for attachment of water, fuel, electrical, vent, and blowdown connections.
  2. The boiler shall be built to comply with the following insurance and codes (Factory Mutual, XL GAP, ASME, NFPA 8501).
- B. Boiler Shell (Steam)
1. The boiler shell must be constructed in accordance with ASME Boiler Code and must receive authorized boiler inspection prior to shipment. A copy of the inspection report shall be furnished to the purchaser.
  2. The boiler shall be furnished with a manhole and handholes to facilitate boiler inspection and cleaning. Two lifting lugs must be located on top of the boiler.
  3. The front smokebox doors shall be davited and sealed with superwool insulation and fastened tightly using locking lugs on steel studs.
  4. The rear head shall be fitted with an access plug for rear fireside inspection.
  5. The boiler tubes shall not include turbulators, swirlers, or other add-on appurtenances.
  6. The exhaust gas vent shall be located at the front of the boiler and be capable of supporting 2000 lbs. The boiler vent shall contain a stack thermometer.
  7. Observation ports for the inspection of flame conditions shall be provided at each end of the boiler.
  8. The boiler insulation shall consist of 2 inch blanket under a sectional pre-formed sheet metal lagging. The insulation must be readily removable and capable of being reinstalled if required.
  9. The entire boiler base frame and other components shall be factory painted before shipment, using a hard-finish enamel coating.
  10. The boiler shall contain a chemical feed connection.

## 2.2 STEAM BOILER TRIM

- A. Water Column/low Water Cutoff And Water Level Control System shall be a CB LEVEL MASTER water level control system and shall comprise a microprocessor-based electronic controller, a non-contact, non-wearing, continuously reading absolute level sensor, and pressure chamber. The control system shall be designed as follows: The electronic controller shall be mounted in the common control panel and operate in ambient temperatures from 32 degrees F to 125 degrees F. The pressure chamber shall be boiler mounted and operate to pressures of 250 PSIG and the level sensor shall operate to pressures of 250 PSIG and temperatures to 400 degrees F. The pressure-containing components shall be constructed in accordance with ASME Code. A shielded, four conductor cable with ground shall be run in metal conduit between the level sensor and the controller. Supply power shall be 115VAC-1 phase- 60 Hz. All wiring shall be in compliance with the National Electrical Code.

The pressure chamber shall have a sight glass mounted on the side. The level sensor shall have an accuracy of .01" or greater. The electronic controller shall have level and error indicating lights, alphanumeric display for messaging, reset/ menu switch and the following features:

- a. Continuous Level Indication
- b. Low Water Cutoff & Alarm
- c. High Water Alarm
- d. Low & High Water Warning
- e. Full Modulating Control of Modulating Feedwater Control Valve
- f. Continuous Monitoring of Float Operation
- g. Column Blowdown Detection and Reminder
- h. Auto or Manual Reset
- i. Real Time Clock
- j. Alarm Annunciation
- k. Alarm History Files with Time Stamp
- l. Water Column Blowdown Record
- m. Auxiliary Low Water Cutoff Check
- n. RS 232 Interface

Maximum Contacts Rating 15 amps Resistive Load

- B. Modulating feedwater Control  
The boiler modulating feedwater control and valve shall be included to automatically maintain the boiler water level within normal limits.
- C. Auxiliary Low Water Cut-off  
Auxiliary low water cut-off shall be included, piped to the vessel, and wired to the burner control circuit. A manual reset device shall be used on this control.
- D. Steam Pressure Gauge  
The steam pressure gauge shall be located at the front of the boiler and include cock and test connection.
- E. Safety Valves  
Safety valves of a type and size to comply with ASME Code requirements shall be shipped loose.
- F. Steam Pressure Controls  
The steam pressure control to regulate burner operation shall be mounted near the water column. Controls shall be a high limit (manual reset), operating limit (auto reset), and firing rate control.

### 2.3 BURNER

- A. Burner shall incorporate Cleaver Brooks “Lean Burn Technology”.
- B. Fuel and air ratio/mixture shall be controlled over the entire operating range, allowing for firing at constant excess air on high turndown burner application.
- C. Burner to be designed specifically for boiler including optimized furnace allowing for low emissions and lean burn combustion.
- D. Mode of Operation
  1. Burner operation shall be full modulation principle. The burner shall always return to low fire position for ignition.
  2. A low fire hold temperature control is mounted and wired on the boiler.
- E. Blower
  1. Air for combustion shall be supplied by a forced draft blower incorporated into the burner design to eliminate vibration and reduce noise level.
  2. Maximum sound level of the boiler/burner package shall not exceed \_\_\_\_\_ dbA (when measured in accordance with ABMA Sound Test Standards).
  3. The impeller shall be fabricated aluminum with radial blade, carefully balanced, and directly connected to the blower motor shaft.
- F. Combustion Air Control  
Combustion air damper and fuel metering valve shall be operated by individual actuators to regulate the flame according to load demand.

### 2.4 FUEL SPECIFICATION AND PIPING

Select one of the following fuel types:

- Fuel series 700 - Gas-fired.
- Fuel series 100 - Light oil (No. 2) fired .
- Fuel series 200 - Light oil or gas-fired.

**NOTE: Specification writer to select between NOx options of 60 ppm, 30 ppm, 9 ppm or 7 ppm Nox on Natural Gas as required for specific project conditions.**

## 60 PPM Nox Operation Natural Gas

### CBEX 100 to 200 Horsepower 60 PPM

- A. Fuel Series 700 - Gas-Fired
  1. Burner type - The burner shall be mounted at the front of the boiler and shall be of high radiant multi-port type gas entry. Burner shall be approved for operation on natural gas fuel.

2. Gas Pilot - The gas pilot shall be a premix type with automatic electric ignition. An electronic detector shall monitor the pilot so that the primary gas valve cannot open until pilot flame has been established. The pilot train shall include one manual shut-off valve, solenoid valve, pressure regulator and one (1) plugged leakage test connection (Canada only).
  3. Gas Burner Piping - Gas burner piping on all units shall include a primary gas shutoff valve, motor operated with proof of closure switch and plugged leakage test connection. The main gas valve shall be wired to close automatically in the event of power failure, flame failure, low water or any safety shutdown condition. A lubricating plug cock shall be provided as a means for a tightness check of the primary shutoff valve. An additional plug cock shall be furnished at entrance to gas train. High and low gas pressure switches shall be provided. A second motorized safety shutoff valve with plugged leakage test connection shall be provided. A vent valve shall be located between the safety shutoff valves. Gas pressure regulator can be offered as an option.
  4. Burner Turndown: Turndown range shall be 4:1 when firing natural gas (consult with Cleaver-Brooks representative regarding high turndown capability based on available gas pressure).
  5. CO on Natural Gas is 10 ppm at 50, 75 and 100 % of firing and 25 ppm at 25% firing rate. Excess air is 15% at 50, 75 and 100% of firing and 30% at 25% firing rate.
- B. Fuel Series 100 - Light Oil-Fired
1. Burner type - The burner shall be mounted at the front of the boiler and shall be a low pressure air atomizing type approved for operation with CS12-48 Commercial No. 2 oil.
  2. Gas Pilot - The gas pilot shall be a premix type with automatic electric ignition. An electronic detector shall monitor the pilot so that the primary oil valve cannot open until pilot flame has been established. The pilot train shall include one manual shut-off valve, solenoid valve, pressure regulator and one (1) plugged leakage test connection (Canada only).
  3. Oil Pump - An oil pump with a capacity of approximately twice the maximum burning rate shall be included. The motor-driven pump set, shipped loose, to be installed in a location favorable to the oil storage tank, shall be provided.
  4. Oil Burner Piping
    - a. Fuel oil piping on the unit shall include oil pressure regulating devices, oil metering controls, low oil pressure switch, two (2) motorized oil valves and pressure gauges, all integrally mounted on the unit.
  5. Low Pressure Air Atomizing: separate air compressor module, shipped loose, with burner mounted low atomizing air pressure switch.
  6. Turndown range shall be 4:1 when firing No. 2 oil.
  7. Excess air is 25% with 10 ppm CO.
- C. Fuel Series 200 - Light Oil or Gas-Fired
1. Burner type - The burner shall be mounted at the front of the boiler and shall be a combination of the low pressure air atomizing type for oil and multi-port type for gas. The burner shall be approved for operation with either CS12-48 Commercial No. 2 oil or natural gas.
  2. Gas Pilot - The gas pilot shall be a premix type with automatic electric ignition. An electronic detector shall monitor the pilot so that the primary fuel valve cannot open until pilot flame has been established. The pilot train shall include one manual shut-off valve, solenoid valve, pressure regulator and one (1) plugged leakage test connection (Canada only).

3. Oil Burner
  - a. Oil Pump - An oil pump with a capacity of approximately twice the maximum burning rate shall be included. The motor-driven pump set, shipped loose, shall be provided, to be installed in a location favorable to the oil storage tank.
  - b. Oil Burner Piping - Fuel oil piping on the unit shall include oil pressure regulating devices, oil metering controls, low oil pressure switch, two (2) motorized oil valves, and pressure gauges all integrally mounted on the unit.
  - c. Low pressure air atomizing - Separate air compressor module, shipped loose with burner-mounted low-atomizing air pressure switch.
  - d. Burner Turndown - Turndown range shall be 4:1 when firing No. 2 oil.
  - e. Excess air is 25% with 10 ppm CO
4. Gas Burner
  - a. Gas Burner Piping - Gas burner piping on all units shall include a primary gas shutoff valve, motor operated with proof of closure switch and plugged leakage test connection. The main gas valve shall be wired to close automatically in the event of power failure, flame failure, low water or any safety shutdown condition. A lubricating plug cock shall be provided as a means for a tightness check of the primary shutoff valve. An additional plug cock shall be furnished at entrance to gas train. High and low gas pressure switches shall be provided. A second motorized safety shutoff valve with plugged leakage test connection shall be provided. A vent valve shall be located between the safety shutoff valves. Gas pressure regulator can be offered as an option.
  - b. Burner Turndown - Turndown range shall be 4:1 when firing natural gas.
  - c. CO on Natural Gas is 10 ppm at 50, 75 and 100 % of firing and 25 ppm at 25% firing rate. Excess air is 15% at 50, 75 and 100% of firing and 30% at 25% firing rate.

### **CBEX 250 and 300 Horsepower 60 PPM**

- A. Fuel Series 700 - Gas-Fired
  1. Burner type - The burner shall be mounted at the front of the boiler and shall be of high radiant multi-port type gas entry. Burner shall be approved for operation on natural gas fuel.
  2. Gas Pilot - The gas pilot shall be a premix type with automatic electric ignition. An electronic detector shall monitor the pilot so that the primary gas valve cannot open until pilot flame has been established. The pilot train shall include one manual shut-off valve, solenoid valve, pressure regulator and one (1) plugged leakage test connection (Canada only).
  3. Gas Burner Piping - Gas burner piping on all units shall include a primary gas shutoff valve, motor operated with proof of closure switch and plugged leakage test connection. The main gas valve shall be wired to close automatically in the event of power failure, flame failure, low water or any safety shutdown condition. A lubricating plug cock shall be provided as a means for a tightness check of the primary shutoff valve. An additional plug cock shall be furnished at entrance to gas train. High and low gas pressure switches shall be provided. A second motorized safety shutoff valve with plugged leakage test connection shall be provided. A vent valve shall be located between the safety shutoff valves. Gas pressure regulator can be offered as an option.
  4. Burner Turndown: Turndown range shall be 10:1 when firing natural gas. VSD required to maintain 3% O<sub>2</sub> over turndown range.

5. CO on Natural Gas is 10 ppm with excess air at 15% in firing range of 50% to 100% increasing to 50 ppm CO at 10:1 turndown.
- B. Fuel Series 100 - Light Oil-Fired
1. Burner type - The burner shall be mounted at the front of the boiler and shall be a low pressure air atomizing type approved for operation with CS12-48 Commercial No. 2 oil.
  2. Gas Pilot - The gas pilot shall be a premix type with automatic electric ignition. An electronic detector shall monitor the pilot so that the primary oil valve cannot open until pilot flame has been established. The pilot train shall include one manual shut-off valve, solenoid valve, pressure regulator and one (1) plugged leakage test connection (Canada only).
  3. Oil Pump - An oil pump with a capacity of approximately twice the maximum burning rate shall be included. The motor-driven pump set, shipped loose, to be installed in a location favorable to the oil storage tank, shall be provided.
  4. Oil Burner Piping
    - a. Fuel oil piping on the unit shall include oil pressure regulating devices, oil metering controls, low oil pressure switch, two (2) motorized oil valves and pressure gauges, all integrally mounted on the unit.
  5. Low Pressure Air Atomizing: separate air compressor module, shipped loose, with burner mounted low atomizing air pressure switch.
  6. Turndown range shall be 7:1 when firing No. 2 oil.
  7. Excess air is 25% with 10 ppm CO.
- C. Fuel Series 200 - Light Oil or Gas-Fired
1. Burner type - The burner shall be mounted at the front of the boiler and shall be a combination of the low pressure air atomizing type for oil and multi-port type for gas. The burner shall be approved for operation with either CS12-48 Commercial No. 2 oil or natural gas.
  2. Gas Pilot - The gas pilot shall be a premix type with automatic electric ignition. An electronic detector shall monitor the pilot so that the primary fuel valve cannot open until pilot flame has been established. The pilot train shall include one manual shut-off valve, solenoid valve, pressure regulator and one (1) plugged leakage test connection (Canada only).
  3. Oil Burner
    - a. Oil Pump - An oil pump with a capacity of approximately twice the maximum burning rate shall be included. The motor-driven pump set, shipped loose, shall be provided, to be installed in a location favorable to the oil storage tank.
    - b. Oil Burner Piping - Fuel oil piping on the unit shall include oil pressure regulating devices, oil metering controls, low oil pressure switch, two (2) motorized oil valves, and pressure gauges all integrally mounted on the unit.
    - c. Low pressure air atomizing - Separate air compressor module, shipped loose with burner-mounted low-atomizing air pressure switch.
    - d. Burner Turndown - Turndown range shall be 7:1 when firing No. 2 oil.
    - e. Excess air is 25% with 10 ppm CO.
  4. Gas Burner
    - a. Gas Burner Piping - Gas burner piping on all units shall include a primary gas shutoff valve, motor operated with proof of closure switch and plugged leakage test connection. The main gas valve shall be wired to close automatically in the event of

power failure, flame failure, low water or any safety shutdown condition. A lubricating plug cock shall be provided as a means for a tightness check of the primary shutoff valve. An additional plug cock shall be furnished at entrance to gas train. High and low gas pressure switches shall be provided. A second motorized safety shutoff valve with plugged leakage test connection shall be provided. A vent valve shall be located between the safety shutoff valves. Gas pressure regulator can be offered as an option.

- b. Burner Turndown - Turndown range shall be 10:1 with 15% excess air when firing natural gas. VSD required to maintain 3% O<sub>2</sub> over turndown range.
- c. CO on Natural Gas is 10 ppm at 50% to 100% firing, increasing to 50 ppm CO at 10:1 turndown

### **CBEX 350 to 800 Horsepower 60 PPM**

#### **A. Fuel Series 700 - Gas-Fired**

1. Burner type - The burner shall be mounted at the front of the boiler and shall be of high radiant multi-port type gas entry. Burner shall be approved for operation on natural gas fuel.
2. Gas Pilot - The gas pilot shall be a premix type with automatic electric ignition. An electronic detector shall monitor the pilot so that the primary gas valve cannot open until pilot flame has been established. The pilot train shall include one manual shut-off valve, solenoid valve, pressure regulator and one (1) plugged leakage test connection (Canada only).
3. Gas Burner Piping - Gas burner piping on all units shall include a primary gas shutoff valve, motor operated with proof of closure switch and plugged leakage test connection. The main gas valve shall be wired to close automatically in the event of power failure, flame failure, low water or any safety shutdown condition. A lubricating plug cock shall be provided as a means for a tightness check of the primary shutoff valve. An additional plug cock shall be furnished at entrance to gas train. High and low gas pressure switches shall be provided. A second motorized safety shutoff valve with plugged leakage test connection shall be provided. A vent valve shall be located between the safety shutoff valves. Gas pressure regulator can be offered as an option.
4. Burner Turndown: Turndown range shall be 10:1 while holding 15% excess air across the turndown range. VSD required to hold excess air across firing range on natural gas.
5. CO on Natural Gas is 10 ppm with excess air at 15%.

#### **B. Fuel Series 100 - Light Oil-Fired**

1. Burner type - The burner shall be mounted at the front of the boiler and shall be a low pressure air atomizing type approved for operation with CS12-48 Commercial No. 2 oil.
2. Gas Pilot - The gas pilot shall be a premix type with automatic electric ignition. An electronic detector shall monitor the pilot so that the primary oil valve cannot open until pilot flame has been established. The pilot train shall include one manual shut-off valve, solenoid valve, pressure regulator and one (1) plugged leakage test connection (Canada only).
3. Oil Pump - An oil pump with a capacity of approximately twice the maximum burning rate shall be included. The motor-driven pump set, shipped loose, to be installed in a location favorable to the oil storage tank, shall be provided.
4. Oil Burner Piping
  - a. Fuel oil piping on the unit shall include oil pressure regulating devices, oil metering controls, low oil pressure switch, two (2) motorized oil valves and pressure gauges,

- all integrally mounted on the unit.
5. Low Pressure Air Atomizing: separate air compressor module, shipped loose, with burner mounted low atomizing air pressure switch.
  6. Turndown range shall be 8:1 when firing No. 2 oil.
  7. Excess air is 25% with 10 ppm CO.
- C. Fuel Series 200 - Light Oil or Gas-Fired
1. Burner type - The burner shall be mounted at the front of the boiler and shall be a combination of the low pressure air atomizing type for oil and multi-port type for gas. The burner shall be approved for operation with either CS12-48 Commercial No. 2 oil or natural gas.
  2. Gas Pilot - The gas pilot shall be a premix type with automatic electric ignition. An electronic detector shall monitor the pilot so that the primary fuel valve cannot open until pilot flame has been established. The pilot train shall include one manual shut-off valve, solenoid valve, pressure regulator and one (1) plugged leakage test connection (Canada only).
  3. Oil Burner
    - a. Oil Pump - An oil pump with a capacity of approximately twice the maximum burning rate shall be included. The motor-driven pump set, shipped loose, shall be provided, to be installed in a location favorable to the oil storage tank.
    - b. Oil Burner Piping - Fuel oil piping on the unit shall include oil pressure regulating devices, oil metering controls, low oil pressure switch, two (2) motorized oil valves, and pressure gauges all integrally mounted on the unit.
    - c. Low pressure air atomizing - Separate air compressor module, shipped loose with burner-mounted low-atomizing air pressure switch.
    - d. Burner Turndown - Turndown range shall be 8:1 when firing No. 2 oil.
    - e. Excess air is 25% with 10 ppm CO.
  4. Gas Burner
    - a. Gas Burner Piping - Gas burner piping on all units shall include a primary gas shutoff valve, motor operated with proof of closure switch and plugged leakage test connection. The main gas valve shall be wired to close automatically in the event of power failure, flame failure, low water or any safety shutdown condition. A lubricating plug cock shall be provided as a means for a tightness check of the primary shutoff valve. An additional plug cock shall be furnished at entrance to gas train. High and low gas pressure switches shall be provided. A second motorized safety shutoff valve with plugged leakage test connection shall be provided. A vent valve shall be located between the safety shutoff valves. Gas pressure regulator can be offered as an option.
    - b. Burner Turndown - Turndown range shall be 10:1 when firing natural gas with 15% excess air over the turndown range. VSD required to maintain excess air over turndown range.
    - c. CO on Natural Gas is 10 ppm with excess air at 15%.

## 30 PPM Nox Operation Natural Gas

### CBEX 100 to 200 Horsepower 30 PPM

## A. Fuel Series 700 - Gas-Fired

1. Burner type - The burner shall be mounted at the front of the boiler and shall be of high radiant multi-port type gas entry. Burner shall be approved for operation on natural gas fuel.
2. Gas Pilot - The gas pilot shall be a premix type with automatic electric ignition. An electronic detector shall monitor the pilot so that the primary gas valve cannot open until pilot flame has been established. The pilot train shall include one manual shut-off valve, solenoid valve, pressure regulator and one (1) plugged leakage test connection (Canada only).
3. Gas Burner Piping - Gas burner piping on all units shall include a primary gas shutoff valve, motor operated with proof of closure switch and plugged leakage test connection. The main gas valve shall be wired to close automatically in the event of power failure, flame failure, low water or any safety shutdown condition. A lubricating plug cock shall be provided as a means for a tightness check of the primary shutoff valve. An additional plug cock shall be furnished at entrance to gas train. High and low gas pressure switches shall be provided. A second motorized safety shutoff valve with plugged leakage test connection shall be provided. A vent valve shall be located between the safety shutoff valves. Gas pressure regulator can be offered as an option.
4. Burner Turndown: Turndown range shall be 4:1 when firing natural gas (consult with Cleaver-Brooks representative regarding high turndown capability based on available gas pressure).
5. CO on Natural Gas is 25 ppm at 50, 75 and 100 % of firing and 50 ppm at 25% firing rate. Excess air is 15% at 50, 75 and 100% of firing and 30% at 25% firing rate.

## B. Fuel Series 100 - Light Oil-Fired

1. Burner type - The burner shall be mounted at the front of the boiler and shall be a low pressure air atomizing type approved for operation with CS12-48 Commercial No. 2 oil.
2. Gas Pilot - The gas pilot shall be a premix type with automatic electric ignition. An electronic detector shall monitor the pilot so that the primary oil valve cannot open until pilot flame has been established. The pilot train shall include one manual shut-off valve, solenoid valve, pressure regulator and one (1) plugged leakage test connection (Canada only).
3. Oil Pump - An oil pump with a capacity of approximately twice the maximum burning rate shall be included. The motor-driven pump set, shipped loose, to be installed in a location favorable to the oil storage tank, shall be provided.
4. Oil Burner Piping
  - a. Fuel oil piping on the unit shall include oil pressure regulating devices, oil metering controls, low oil pressure switch, two (2) motorized oil valves and pressure gauges, all integrally mounted on the unit.
5. Low Pressure Air Atomizing: separate air compressor module, shipped loose, with burner mounted low atomizing air pressure switch.
6. Turndown range shall be 4:1 when firing No. 2 oil.
7. Excess air is 25% with 10 ppm CO.

## C. Fuel Series 200 - Light Oil or Gas-Fired

1. Burner type - The burner shall be mounted at the front of the boiler and shall be a combination of the low pressure air atomizing type for oil and multi-port type for gas. The burner shall be approved for operation with either CS12-48 Commercial No. 2 oil or

- natural gas.
2. Gas Pilot - The gas pilot shall be a premix type with automatic electric ignition. An electronic detector shall monitor the pilot so that the primary fuel valve cannot open until pilot flame has been established. The pilot train shall include one manual shut-off valve, solenoid valve, pressure regulator and one (1) plugged leakage test connection (Canada only).
  3. Oil Burner
    - a. Oil Pump - An oil pump with a capacity of approximately twice the maximum burning rate shall be included. The motor-driven pump set, shipped loose, shall be provided, to be installed in a location favorable to the oil storage tank.
    - b. Oil Burner Piping - Fuel oil piping on the unit shall include oil pressure regulating devices, oil metering controls, low oil pressure switch, two (2) motorized oil valves, and pressure gauges all integrally mounted on the unit.
    - c. Low pressure air atomizing - Separate air compressor module, shipped loose with burner-mounted low-atomizing air pressure switch.
    - d. Burner Turndown - Turndown range shall be 4:1 when firing No. 2 oil.
    - e. Excess air is 25% with 10 ppm CO.
  4. Gas Burner
    - a. Gas Burner Piping - Gas burner piping on all units shall include a primary gas shutoff valve, motor operated with proof of closure switch and plugged leakage test connection. The main gas valve shall be wired to close automatically in the event of power failure, flame failure, low water or any safety shutdown condition. A lubricating plug cock shall be provided as a means for a tightness check of the primary shutoff valve. An additional plug cock shall be furnished at entrance to gas train. High and low gas pressure switches shall be provided. A second motorized safety shutoff valve with plugged leakage test connection shall be provided. A vent valve shall be located between the safety shutoff valves. Gas pressure regulator can be offered as an option.
    - b. Burner Turndown - Turndown range shall be 4:1 when firing natural gas.
    - c. CO on Natural Gas is 25 ppm at 50, 75 and 100 % of firing and 50 ppm at 25% firing rate. Excess air is 15% at 50, 75 and 100% of firing and 30% at 25% firing rate.

### **CBEX 250 and 300 Horsepower 30 PPM**

- A. Fuel Series 700 - Gas-Fired
  1. Burner type - The burner shall be mounted at the front of the boiler and shall be of high radiant multi-port type gas entry. Burner shall be approved for operation on natural gas fuel.
  2. Gas Pilot - The gas pilot shall be a premix type with automatic electric ignition. An electronic detector shall monitor the pilot so that the primary gas valve cannot open until pilot flame has been established. The pilot train shall include one manual shut-off valve, solenoid valve, pressure regulator and one (1) plugged leakage test connection (Canada only).

3. Gas Burner Piping - Gas burner piping on all units shall include a primary gas shutoff valve, motor operated with proof of closure switch and plugged leakage test connection. The main gas valve shall be wired to close automatically in the event of power failure, flame failure, low water or any safety shutdown condition. A lubricating plug cock shall be provided as a means for a tightness check of the primary shutoff valve. An additional plug cock shall be furnished at entrance to gas train. High and low gas pressure switches shall be provided. A second motorized safety shutoff valve with plugged leakage test connection shall be provided. A vent valve shall be located between the safety shutoff valves. Gas pressure regulator can be offered as an option.
  4. Burner Turndown: Turndown range shall be 10:1 when firing natural gas with 15% excess air across the firing range. VSD is required to hold 15% excess air across the firing range.
  5. CO on Natural Gas is 10 ppm with excess air at 15%, from 50% to 100% firing. CO will increase to 50 ppm at 10:1 turndown.
- B. Fuel Series 100 - Light Oil-Fired
1. Burner type - The burner shall be mounted at the front of the boiler and shall be a low pressure air atomizing type approved for operation with CS12-48 Commercial No. 2 oil.
  2. Gas Pilot - The gas pilot shall be a premix type with automatic electric ignition. An electronic detector shall monitor the pilot so that the primary oil valve cannot open until pilot flame has been established. The pilot train shall include one manual shut-off valve, solenoid valve, pressure regulator and one (1) plugged leakage test connection (Canada only).
  3. Oil Pump - An oil pump with a capacity of approximately twice the maximum burning rate shall be included. The motor-driven pump set, shipped loose, to be installed in a location favorable to the oil storage tank, shall be provided.
  4. Oil Burner Piping
    - a. Fuel oil piping on the unit shall include oil pressure regulating devices, oil metering controls, low oil pressure switch, two (2) motorized oil valves and pressure gauges, all integrally mounted on the unit.
  5. Low Pressure Air Atomizing: separate air compressor module, shipped loose, with burner mounted low atomizing air pressure switch.
  6. Turndown range shall be 7:1 when firing No. 2 oil.
  7. Excess air is 25% with 10 ppm CO.
- C. Fuel Series 200 - Light Oil or Gas-Fired
1. Burner type - The burner shall be mounted at the front of the boiler and shall be a combination of the low pressure air atomizing type for oil and multi-port type for gas. The burner shall be approved for operation with either CS12-48 Commercial No. 2 oil or natural gas.
  2. Gas Pilot - The gas pilot shall be a premix type with automatic electric ignition. An electronic detector shall monitor the pilot so that the primary fuel valve cannot open until pilot flame has been established. The pilot train shall include one manual shut-off valve, solenoid valve, pressure regulator and one (1) plugged leakage test connection (Canada only).
  3. Oil Burner
    - b. Oil Pump - An oil pump with a capacity of approximately twice the maximum burning rate shall be included. The motor-driven pump set, shipped loose, shall be provided, to be installed in a location favorable to the oil storage tank.

- c. Oil Burner Piping - Fuel oil piping on the unit shall include oil pressure regulating devices, oil metering controls, low oil pressure switch, two (2) motorized oil valves, and pressure gauges all integrally mounted on the unit.
  - d. Low pressure air atomizing - Separate air compressor module, shipped loose with burner-mounted low-atomizing air pressure switch.
  - e. Burner Turndown - Turndown range shall be 7:1 when firing No. 2 oil.
  - f. Excess air is 25% with 10 ppm CO.
4. Gas Burner
- a. Gas Burner Piping - Gas burner piping on all units shall include a primary gas shutoff valve, motor operated with proof of closure switch and plugged leakage test connection. The main gas valve shall be wired to close automatically in the event of power failure, flame failure, low water or any safety shutdown condition. A lubricating plug cock shall be provided as a means for a tightness check of the primary shutoff valve. An additional plug cock shall be furnished at entrance to gas train. High and low gas pressure switches shall be provided. A second motorized safety shutoff valve with plugged leakage test connection shall be provided. A vent valve shall be located between the safety shutoff valves. Gas pressure regulator can be offered as an option.
  - b. Burner Turndown - Turndown range shall be 10:1 when firing natural gas with 15% excess air over the turndown range. VSD required to hold excess air over the turndown range.
  - c. CO on Natural Gas is 10 ppm with excess air at 15%, from 50% to 100% rating. CO will increase to 50 ppm at turndown of 10:1.

### **CBEX 350 to 800 Horsepower 30 PPM**

- A. Fuel Series 700 - Gas-Fired
- 1. Burner type - The burner shall be mounted at the front of the boiler and shall be of high radiant multi-port type gas entry. Burner shall be approved for operation on natural gas fuel.
  - 2. Gas Pilot - The gas pilot shall be a premix type with automatic electric ignition. An electronic detector shall monitor the pilot so that the primary gas valve cannot open until pilot flame has been established. The pilot train shall include one manual shut-off valve, solenoid valve, pressure regulator and one (1) plugged leakage test connection (Canada only).
  - 3. Gas Burner Piping - Gas burner piping on all units shall include a primary gas shutoff valve, motor operated with proof of closure switch and plugged leakage test connection. The main gas valve shall be wired to close automatically in the event of power failure, flame failure, low water or any safety shutdown condition. A lubricating plug cock shall be provided as a means for a tightness check of the primary shutoff valve. An additional plug cock shall be furnished at entrance to gas train. High and low gas pressure switches shall be provided. A second motorized safety shutoff valve with plugged leakage test connection shall be provided. A vent valve shall be located between the safety shutoff valves. Gas pressure regulator can be offered as an option.
  - 4. Burner Turndown: Turndown range shall be 10:1 while holding 15% excess air across the turndown range. VSD required to hold excess air across firing range on natural gas.
  - 5. CO on Natural Gas is 10 ppm with excess air at 15%.
- B. Fuel Series 100 - Light Oil-Fired
- 1. Burner type - The burner shall be mounted at the front of the boiler and shall be a low

- pressure air atomizing type approved for operation with CS12-48 Commercial No. 2 oil.
2. Gas Pilot - The gas pilot shall be a premix type with automatic electric ignition. An electronic detector shall monitor the pilot so that the primary oil valve cannot open until pilot flame has been established. The pilot train shall include one manual shut-off valve, solenoid valve, pressure regulator and one (1) plugged leakage test connection (Canada only).
  3. Oil Pump - An oil pump with a capacity of approximately twice the maximum burning rate shall be included. The motor-driven pump set, shipped loose, to be installed in a location favorable to the oil storage tank, shall be provided.
  4. Oil Burner Piping
    - a. Fuel oil piping on the unit shall include oil pressure regulating devices, oil metering controls, low oil pressure switch, two (2) motorized oil valves and pressure gauges, all integrally mounted on the unit.
  5. Low Pressure Air Atomizing: separate air compressor module, shipped loose, with burner mounted low atomizing air pressure switch.
  6. Turndown range shall be 8:1 when firing No. 2 oil.
  7. Excess air is 25% with 10 ppm CO.
- C. Fuel Series 200 - Light Oil or Gas-Fired
1. Burner type - The burner shall be mounted at the front of the boiler and shall be a combination of the low pressure air atomizing type for oil and multi-port type for gas. The burner shall be approved for operation with either CS12-48 Commercial No. 2 oil or natural gas.
  2. Gas Pilot - The gas pilot shall be a premix type with automatic electric ignition. An electronic detector shall monitor the pilot so that the primary fuel valve cannot open until pilot flame has been established. The pilot train shall include one manual shut-off valve, solenoid valve, pressure regulator and one (1) plugged leakage test connection (Canada only).
  3. Oil Burner
    - a. Oil Pump - An oil pump with a capacity of approximately twice the maximum burning rate shall be included. The motor-driven pump set, shipped loose, shall be provided, to be installed in a location favorable to the oil storage tank.
    - b. Oil Burner Piping - Fuel oil piping on the unit shall include oil pressure regulating devices, oil metering controls, low oil pressure switch, two (2) motorized oil valves, and pressure gauges all integrally mounted on the unit.
    - c. Low pressure air atomizing - Separate air compressor module, shipped loose with burner-mounted low-atomizing air pressure switch.
    - d. Burner Turndown - Turndown range shall be 8:1 when firing No. 2 oil.
    - e. Excess air is 25% with 10 ppm CO.
  4. Gas Burner
    - a. Gas Burner Piping - Gas burner piping on all units shall include a primary gas shutoff valve, motor operated with proof of closure switch and plugged leakage test connection. The main gas valve shall be wired to close automatically in the event of power failure, flame failure, low water or any safety shutdown condition. A lubricating plug cock shall be provided as a means for a tightness check of the primary shutoff valve. An additional plug cock shall be furnished at entrance to gas train. High and low gas pressure switches shall be provided. A second motorized safety shutoff valve with plugged leakage test connection shall be provided. A vent valve shall be located

- between the safety shutoff valves. Gas pressure regulator can be offered as an option.
- b. Burner Turndown - Turndown range shall be 10:1 while holding 15% excess air across the turndown range. VSD required to hold excess air across firing range on natural gas.
  - c. CO on Natural Gas is 10 ppm with excess air at 15%.

## 9 PPM Nox Operation Natural Gas

### CBEX 100 to 200 Horsepower 9 PPM

- A. Fuel Series 700 - Gas-Fired
  1. Burner type - The burner shall be mounted at the front of the boiler and shall be of high radiant multi-port type gas entry. Burner shall be approved for operation on natural gas fuel.
  2. Gas Pilot - The gas pilot shall be a premix type with automatic electric ignition. An electronic detector shall monitor the pilot so that the primary gas valve cannot open until pilot flame has been established. The pilot train shall include one manual shut-off valve, solenoid valve, pressure regulator and one (1) plugged leakage test connection (Canada only).
  3. Gas Burner Piping - Gas burner piping on all units shall include a primary gas shutoff valve, motor operated with proof of closure switch and plugged leakage test connection. The main gas valve shall be wired to close automatically in the event of power failure, flame failure, low water or any safety shutdown condition. A lubricating plug cock shall be provided as a means for a tightness check of the primary shutoff valve. An additional plug cock shall be furnished at entrance to gas train. High and low gas pressure switches shall be provided. A second motorized safety shutoff valve with plugged leakage test connection shall be provided. A vent valve shall be located between the safety shutoff valves. Gas pressure regulator can be offered as an option.
  4. Burner Turndown: Turndown range shall be 4:1 when firing natural gas (consult with Cleaver-Brooks representative regarding high turndown capability based on available gas pressure).
  5. CO on Natural Gas is 25 ppm with excess air at 25%.
- B. Fuel Series 100 - Light Oil-Fired
  1. Burner type - The burner shall be mounted at the front of the boiler and shall be a low pressure air atomizing type approved for operation with CS12-48 Commercial No. 2 oil.
  2. Gas Pilot - The gas pilot shall be a premix type with automatic electric ignition. An electronic detector shall monitor the pilot so that the primary oil valve cannot open until pilot flame has been established. The pilot train shall include one manual shut-off valve, solenoid valve, pressure regulator and one (1) plugged leakage test connection (Canada only).
  3. Oil Pump - An oil pump with a capacity of approximately twice the maximum burning rate shall be included. The motor-driven pump set, shipped loose, to be installed in a location favorable to the oil storage tank, shall be provided.
  4. Oil Burner Piping
    - a. Fuel oil piping on the unit shall include oil pressure regulating devices, oil metering controls, low oil pressure switch, two (2) motorized oil valves and pressure gauges, all integrally mounted on the unit.

5. Low Pressure Air Atomizing: separate air compressor module, shipped loose, with burner mounted low atomizing air pressure switch.
  6. Turndown range shall be 4:1 when firing No. 2 oil.
  7. Excess air is 25% with 10 ppm CO.
- C. Fuel Series 200 - Light Oil or Gas-Fired
1. Burner type - The burner shall be mounted at the front of the boiler and shall be a combination of the low pressure air atomizing type for oil and multi-port type for gas. The burner shall be approved for operation with either CS12-48 Commercial No. 2 oil or natural gas.
  2. Gas Pilot - The gas pilot shall be a premix type with automatic electric ignition. An electronic detector shall monitor the pilot so that the primary fuel valve cannot open until pilot flame has been established. The pilot train shall include one manual shut-off valve, solenoid valve, pressure regulator and one (1) plugged leakage test connection (Canada only).
  3. Oil Burner
    - a. Oil Pump - An oil pump with a capacity of approximately twice the maximum burning rate shall be included. The motor-driven pump set, shipped loose, shall be provided, to be installed in a location favorable to the oil storage tank.
    - b. Oil Burner Piping - Fuel oil piping on the unit shall include oil pressure regulating devices, oil metering controls, low oil pressure switch, two (2) motorized oil valves, and pressure gauges all integrally mounted on the unit.
    - c. Low pressure air atomizing - Separate air compressor module, shipped loose with burner-mounted low-atomizing air pressure switch.
    - d. Burner Turndown - Turndown range shall be 4:1 when firing No. 2 oil.
    - e. Excess air is 25% with 10 ppm CO.
  4. Gas Burner
    - a. Gas Burner Piping - Gas burner piping on all units shall include a primary gas shutoff valve, motor operated with proof of closure switch and plugged leakage test connection. The main gas valve shall be wired to close automatically in the event of power failure, flame failure, low water or any safety shutdown condition. A lubricating plug cock shall be provided as a means for a tightness check of the primary shutoff valve. An additional plug cock shall be furnished at entrance to gas train. High and low gas pressure switches shall be provided. A second motorized safety shutoff valve with plugged leakage test connection shall be provided. A vent valve shall be located between the safety shutoff valves. Gas pressure regulator can be offered as an option.
    - b. Burner Turndown - Turndown range shall be 4:1 when firing natural gas.
    - c. CO on Natural Gas is 25 ppm with excess air at 25%.

### **CBEX 250 to 400 Horsepower 9 PPM**

- A. Fuel Series 700 - Gas-Fired
1. Burner type - The burner shall be mounted at the front of the boiler and shall be of high radiant multi-port type gas entry. Burner shall be approved for operation on natural gas fuel.

2. Gas Pilot - The gas pilot shall be a premix type with automatic electric ignition. An electronic detector shall monitor the pilot so that the primary gas valve cannot open until pilot flame has been established. The pilot train shall include one manual shut-off valve, solenoid valve, pressure regulator and one (1) plugged leakage test connection (Canada only).
  3. Gas Burner Piping - Gas burner piping on all units shall include a primary gas shutoff valve, motor operated with proof of closure switch and plugged leakage test connection. The main gas valve shall be wired to close automatically in the event of power failure, flame failure, low water or any safety shutdown condition. A lubricating plug cock shall be provided as a means for a tightness check of the primary shutoff valve. An additional plug cock shall be furnished at entrance to gas train. High and low gas pressure switches shall be provided. A second motorized safety shutoff valve with plugged leakage test connection shall be provided. A vent valve shall be located between the safety shutoff valves. Gas pressure regulator can be offered as an option.
  4. Burner Turndown: Turndown range shall be 5:1 when firing natural gas (consult with Cleaver-Brooks representative regarding high turndown capability based on available gas pressure).
  5. CO on Natural Gas is 25 ppm with excess air at 25%.
- B. Fuel Series 100 - Light Oil-Fired
1. Burner type - The burner shall be mounted at the front of the boiler and shall be a low pressure air atomizing type approved for operation with CS12-48 Commercial No. 2 oil.
  2. Gas Pilot - The gas pilot shall be a premix type with automatic electric ignition. An electronic detector shall monitor the pilot so that the primary oil valve cannot open until pilot flame has been established. The pilot train shall include one manual shut-off valve, solenoid valve, pressure regulator and one (1) plugged leakage test connection (Canada only).
  3. Oil Pump - An oil pump with a capacity of approximately twice the maximum burning rate shall be included. The motor-driven pump set, shipped loose, to be installed in a location favorable to the oil storage tank, shall be provided.
  4. Oil Burner Piping
    - a. Fuel oil piping on the unit shall include oil pressure regulating devices, oil metering controls, low oil pressure switch, two (2) motorized oil valves and pressure gauges, all integrally mounted on the unit.
  5. Low Pressure Air Atomizing: separate air compressor module, shipped loose, with burner mounted low atomizing air pressure switch.
  6. Turndown range shall be 5:1 when firing No. 2 oil.
  7. Excess air is 25% with 10 ppm CO.
- C. Fuel Series 200 - Light Oil or Gas-Fired
1. Burner type - The burner shall be mounted at the front of the boiler and shall be a combination of the low pressure air atomizing type for oil and multi-port type for gas. The burner shall be approved for operation with either CS12-48 Commercial No. 2 oil or natural gas.
  2. Gas Pilot - The gas pilot shall be a premix type with automatic electric ignition. An electronic detector shall monitor the pilot so that the primary fuel valve cannot open until pilot flame has been established. The pilot train shall include one manual shut-off valve, solenoid valve, pressure regulator and one (1) plugged leakage test connection (Canada only).

3. Oil Burner
  - a. Oil Pump - An oil pump with a capacity of approximately twice the maximum burning rate shall be included. The motor-driven pump set, shipped loose, shall be provided, to be installed in a location favorable to the oil storage tank.
  - b. Oil Burner Piping - Fuel oil piping on the unit shall include oil pressure regulating devices, oil metering controls, low oil pressure switch, two (2) motorized oil valves, and pressure gauges all integrally mounted on the unit.
  - c. Low pressure air atomizing - Separate air compressor module, shipped loose with burner-mounted low-atomizing air pressure switch.
  - d. Burner Turndown - Turndown range shall be 5:1 when firing No. 2 oil.
  - e. Excess air is 25% with 10 ppm CO.
4. Gas Burner
  - a. Gas Burner Piping - Gas burner piping on all units shall include a primary gas shutoff valve, motor operated with proof of closure switch and plugged leakage test connection. The main gas valve shall be wired to close automatically in the event of power failure, flame failure, low water or any safety shutdown condition. A lubricating plug cock shall be provided as a means for a tightness check of the primary shutoff valve. An additional plug cock shall be furnished at entrance to gas train. High and low gas pressure switches shall be provided. A second motorized safety shutoff valve with plugged leakage test connection shall be provided. A vent valve shall be located between the safety shutoff valves. Gas pressure regulator can be offered as an option.
  - b. Burner Turndown - Turndown range shall be 5:1 when firing natural gas.
  - c. CO on Natural Gas is 25 ppm with excess air at 25%.

### **CBEX 500 and 600 Horsepower 9 PPM**

- A. Fuel Series 700 - Gas-Fired
  1. Burner type - The burner shall be mounted at the front of the boiler and shall be of high radiant multi-port type gas entry. Burner shall be approved for operation on natural gas fuel.
  2. Gas Pilot - The gas pilot shall be a premix type with automatic electric ignition. An electronic detector shall monitor the pilot so that the primary gas valve cannot open until pilot flame has been established. The pilot train shall include one manual shut-off valve, solenoid valve, pressure regulator and one (1) plugged leakage test connection (Canada only).
  3. Gas Burner Piping - Gas burner piping on all units shall include a primary gas shutoff valve, motor operated with proof of closure switch and plugged leakage test connection. The main gas valve shall be wired to close automatically in the event of power failure, flame failure, low water or any safety shutdown condition. A lubricating plug cock shall be provided as a means for a tightness check of the primary shutoff valve. An additional plug cock shall be furnished at entrance to gas train. High and low gas pressure switches shall be provided. A second motorized safety shutoff valve with plugged leakage test connection shall be provided. A vent valve shall be located between the safety shutoff valves. Gas pressure regulator can be offered as an option.

4. Burner Turndown: Turndown range shall be 6:1 when firing natural gas (consult with Cleaver-Brooks representative regarding high turndown capability based on available gas pressure).
5. CO on Natural Gas is 25 ppm with excess air at 25%.
- B. Fuel Series 100 - Light Oil-Fired
  1. Burner type - The burner shall be mounted at the front of the boiler and shall be a low pressure air atomizing type approved for operation with CS12-48 Commercial No. 2 oil.
  2. Gas Pilot - The gas pilot shall be a premix type with automatic electric ignition. An electronic detector shall monitor the pilot so that the primary oil valve cannot open until pilot flame has been established. The pilot train shall include one manual shut-off valve, solenoid valve, pressure regulator and one (1) plugged leakage test connection (Canada only).
  3. Oil Pump - An oil pump with a capacity of approximately twice the maximum burning rate shall be included. The motor-driven pump set, shipped loose, to be installed in a location favorable to the oil storage tank, shall be provided.
  4. Oil Burner Piping
    - a. Fuel oil piping on the unit shall include oil pressure regulating devices, oil metering controls, low oil pressure switch, two (2) motorized oil valves and pressure gauges, all integrally mounted on the unit.
  5. Low Pressure Air Atomizing: separate air compressor module, shipped loose, with burner mounted low atomizing air pressure switch.
  6. Turndown range shall be 6:1 when firing No. 2 oil.
  7. Excess air is 25% with 10 ppm CO.
- C. Fuel Series 200 - Light Oil or Gas-Fired
  1. Burner type - The burner shall be mounted at the front of the boiler and shall be a combination of the low pressure air atomizing type for oil and multi-port type for gas. The burner shall be approved for operation with either CS12-48 Commercial No. 2 oil or natural gas.
  2. Gas Pilot - The gas pilot shall be a premix type with automatic electric ignition. An electronic detector shall monitor the pilot so that the primary fuel valve cannot open until pilot flame has been established. The pilot train shall include one manual shut-off valve, solenoid valve, pressure regulator and one (1) plugged leakage test connection (Canada only).
  3. Oil Burner
    - a. Oil Pump - An oil pump with a capacity of approximately twice the maximum burning rate shall be included. The motor-driven pump set, shipped loose, shall be provided, to be installed in a location favorable to the oil storage tank.
    - b. Oil Burner Piping - Fuel oil piping on the unit shall include oil pressure regulating devices, oil metering controls, low oil pressure switch, two (2) motorized oil valves, and pressure gauges all integrally mounted on the unit.
    - c. Low pressure air atomizing - Separate air compressor module, shipped loose with burner-mounted low-atomizing air pressure switch.
    - d. Burner Turndown - Turndown range shall be 6:1 when firing No. 2 oil.
    - e. Excess air is 25% with 10 ppm CO.
  4. Gas Burner
    - a. Gas Burner Piping - Gas burner piping on all units shall include a primary gas shutoff

valve, motor operated with proof of closure switch and plugged leakage test connection. The main gas valve shall be wired to close automatically in the event of power failure, flame failure, low water or any safety shutdown condition. A lubricating plug cock shall be provided as a means for a tightness check of the primary shutoff valve. An additional plug cock shall be furnished at entrance to gas train. High and low gas pressure switches shall be provided. A second motorized safety shutoff valve with plugged leakage test connection shall be provided. A vent valve shall be located between the safety shutoff valves. Gas pressure regulator can be offered as an option.

- b. Burner Turndown - Turndown range shall be 6:1 when firing natural gas.
- c. CO on Natural Gas is 25 ppm with excess air at 25%.

### **CBEX 700 and 800 Horsepower 9 PPM**

#### **A. Fuel Series 700 - Gas-Fired**

- 1. Burner type - The burner shall be mounted at the front of the boiler and shall be of high radiant multi-port type gas entry. Burner shall be approved for operation on natural gas fuel.
- 2. Gas Pilot - The gas pilot shall be a premix type with automatic electric ignition. An electronic detector shall monitor the pilot so that the primary gas valve cannot open until pilot flame has been established. The pilot train shall include one manual shut-off valve, solenoid valve, pressure regulator and one (1) plugged leakage test connection (Canada only).
- 3. Gas Burner Piping - Gas burner piping on all units shall include a primary gas shutoff valve, motor operated with proof of closure switch and plugged leakage test connection. The main gas valve shall be wired to close automatically in the event of power failure, flame failure, low water or any safety shutdown condition. A lubricating plug cock shall be provided as a means for a tightness check of the primary shutoff valve. An additional plug cock shall be furnished at entrance to gas train. High and low gas pressure switches shall be provided. A second motorized safety shutoff valve with plugged leakage test connection shall be provided. A vent valve shall be located between the safety shutoff valves. Gas pressure regulator can be offered as an option.
- 4. Burner Turndown: Turndown range shall be 7:1 when firing natural gas (consult with Cleaver-Brooks representative regarding high turndown capability based on available gas pressure).
- 5. CO on Natural Gas is 25 ppm with excess air at 25%.

#### **B. Fuel Series 100 - Light Oil-Fired**

- 1. Burner type - The burner shall be mounted at the front of the boiler and shall be a low pressure air atomizing type approved for operation with CS12-48 Commercial No. 2 oil.
- 2. Gas Pilot - The gas pilot shall be a premix type with automatic electric ignition. An electronic detector shall monitor the pilot so that the primary oil valve cannot open until pilot flame has been established. The pilot train shall include one manual shut-off valve, solenoid valve, pressure regulator and one (1) plugged leakage test connection (Canada only).
- 3. Oil Pump - An oil pump with a capacity of approximately twice the maximum burning rate shall be included. The motor-driven pump set, shipped loose, to be installed in a location favorable to the oil storage tank, shall be provided.
- 4. Oil Burner Piping
  - a. Fuel oil piping on the unit shall include oil pressure regulating devices, oil

- metering controls, low oil pressure switch, two (2) motorized oil valves and pressure gauges, all integrally mounted on the unit.
5. Low Pressure Air Atomizing: separate air compressor module, shipped loose, with burner mounted low atomizing air pressure switch.
  6. Turndown range shall be 7:1 when firing No. 2 oil.
  7. Excess air is 25% with 10 ppm CO.
- C. Fuel Series 200 - Light Oil or Gas-Fired
1. Burner type - The burner shall be mounted at the front of the boiler and shall be a combination of the low pressure air atomizing type for oil and multi-port type for gas. The burner shall be approved for operation with either CS12-48 Commercial No. 2 oil or natural gas.
  2. Gas Pilot - The gas pilot shall be a premix type with automatic electric ignition. An electronic detector shall monitor the pilot so that the primary fuel valve cannot open until pilot flame has been established. The pilot train shall include one manual shut-off valve, solenoid valve, pressure regulator and one (1) plugged leakage test connection (Canada only).
  3. Oil Burner
    - a. Oil Pump - An oil pump with a capacity of approximately twice the maximum burning rate shall be included. The motor-driven pump set, shipped loose, shall be provided, to be installed in a location favorable to the oil storage tank.
    - b. Oil Burner Piping - Fuel oil piping on the unit shall include oil pressure regulating devices, oil metering controls, low oil pressure switch, two (2) motorized oil valves, and pressure gauges all integrally mounted on the unit.
    - c. Low pressure air atomizing - Separate air compressor module, shipped loose with burner-mounted low-atomizing air pressure switch.
    - d. Burner Turndown - Turndown range shall be 7:1 when firing No. 2 oil.
    - e. Excess air is 25% with 10 ppm CO.
  4. Gas Burner
    - a. Gas Burner Piping - Gas burner piping on all units shall include a primary gas shutoff valve, motor operated with proof of closure switch and plugged leakage test connection. The main gas valve shall be wired to close automatically in the event of power failure, flame failure, low water or any safety shutdown condition. A lubricating plug cock shall be provided as a means for a tightness check of the primary shutoff valve. An additional plug cock shall be furnished at entrance to gas train. High and low gas pressure switches shall be provided. A second motorized safety shutoff valve with plugged leakage test connection shall be provided. A vent valve shall be located between the safety shutoff valves. Gas pressure regulator can be offered as an option.
    - b. Burner Turndown - Turndown range shall be 7:1 when firing natural gas.
    - c. CO on Natural Gas is 25 ppm with excess air at 25%.

## 7 PPM Nox Operation Natural Gas

### CBEX 100 to 200 Horsepower 7 PPM

- A. Fuel Series 700 - Gas-Fired
1. Burner type - The burner shall be mounted at the front of the boiler and shall be of high radiant multi-port type gas entry. Burner shall be approved for operation on natural gas fuel.
  2. Gas Pilot - The gas pilot shall be a premix type with automatic electric ignition. An electronic detector shall monitor the pilot so that the primary gas valve cannot open until pilot flame has been established. The pilot train shall include one manual shut-off valve, solenoid valve, pressure regulator and one (1) plugged leakage test connection (Canada only).
  3. Gas Burner Piping - Gas burner piping on all units shall include a primary gas shutoff valve, motor operated with proof of closure switch and plugged leakage test connection. The main gas valve shall be wired to close automatically in the event of power failure, flame failure, low water or any safety shutdown condition. A lubricating plug cock shall be provided as a means for a tightness check of the primary shutoff valve. An additional plug cock shall be furnished at entrance to gas train. High and low gas pressure switches shall be provided. A second motorized safety shutoff valve with plugged leakage test connection shall be provided. A vent valve shall be located between the safety shutoff valves. Gas pressure regulator can be offered as an option.
  4. Burner Turndown: Turndown range shall be 3:1 when firing natural gas (consult with Cleaver-Brooks representative regarding high turndown capability based on available gas pressure).
  5. CO on Natural Gas is 50 ppm with excess air at 30%.
- B. Fuel Series 100 - Light Oil-Fired
1. Burner type - The burner shall be mounted at the front of the boiler and shall be a low pressure air atomizing type approved for operation with CS12-48 Commercial No. 2 oil.
  2. Gas Pilot - The gas pilot shall be a premix type with automatic electric ignition. An electronic detector shall monitor the pilot so that the primary oil valve cannot open until pilot flame has been established. The pilot train shall include one manual shut-off valve, solenoid valve, pressure regulator and one (1) plugged leakage test connection (Canada only).
  3. Oil Pump - An oil pump with a capacity of approximately twice the maximum burning rate shall be included. The motor-driven pump set, shipped loose, to be installed in a location favorable to the oil storage tank, shall be provided.
  4. Oil Burner Piping
    - a. Fuel oil piping on the unit shall include oil pressure regulating devices, oil metering controls, low oil pressure switch, two (2) motorized oil valves and pressure gauges, all integrally mounted on the unit.
  5. Low Pressure Air Atomizing: separate air compressor module, shipped loose, with burner mounted low atomizing air pressure switch.
  6. Turndown range shall be 3:1 when firing No. 2 oil.
  7. Excess air is 25% with 10 ppm CO.

- C. Fuel Series 200 - Light Oil or Gas-Fired
1. Burner type - The burner shall be mounted at the front of the boiler and shall be a combination of the low pressure air atomizing type for oil and multi-port type for gas. The burner shall be approved for operation with either CS12-48 Commercial No. 2 oil or natural gas.
  2. Gas Pilot - The gas pilot shall be a premix type with automatic electric ignition. An electronic detector shall monitor the pilot so that the primary fuel valve cannot open until pilot flame has been established. The pilot train shall include one manual shut-off valve, solenoid valve, pressure regulator and one (1) plugged leakage test connection (Canada only).
  3. Oil Burner
    - a. Oil Pump - An oil pump with a capacity of approximately twice the maximum burning rate shall be included. The motor-driven pump set, shipped loose, shall be provided, to be installed in a location favorable to the oil storage tank.
    - b. Oil Burner Piping - Fuel oil piping on the unit shall include oil pressure regulating devices, oil metering controls, low oil pressure switch, two (2) motorized oil valves, b. and pressure gauges all integrally mounted on the unit.
    - c. Low pressure air atomizing - Separate air compressor module, shipped loose with burner-mounted low-atomizing air pressure switch.
    - d. Burner Turndown - Turndown range shall be 3:1 when firing No. 2 oil.
    - e. Excess air is 25% with 10 ppm CO.
  4. Gas Burner
    - a. Gas Burner Piping - Gas burner piping on all units shall include a primary gas shutoff valve, motor operated with proof of closure switch and plugged leakage test connection. The main gas valve shall be wired to close automatically in the event of power failure, flame failure, low water or any safety shutdown condition. A lubricating plug cock shall be provided as a means for a tightness check of the primary shutoff valve. An additional plug cock shall be furnished at entrance to gas train. High and low gas pressure switches shall be provided. A second motorized safety shutoff valve with plugged leakage test connection shall be provided. A vent valve shall be located between the safety shutoff valves. Gas pressure regulator can be offered as an option.
    - b. Burner Turndown - Turndown range shall be 3:1 when firing natural gas.
    - c. CO on Natural Gas is 50 ppm with excess air at 30%.

### **CBEX 250 to 500 Horsepower 7 PPM**

- A. Fuel Series 700 - Gas-Fired
1. Burner type - The burner shall be mounted at the front of the boiler and shall be of high radiant multi-port type gas entry. Burner shall be approved for operation on natural gas fuel.
  2. Gas Pilot - The gas pilot shall be a premix type with automatic electric ignition. An electronic detector shall monitor the pilot so that the primary gas valve cannot open until pilot flame has been established. The pilot train shall include one manual shut-off valve, solenoid valve, pressure regulator and one (1) plugged leakage test connection (Canada only).

3. Gas Burner Piping - Gas burner piping on all units shall include a primary gas shutoff valve, motor operated with proof of closure switch and plugged leakage test connection. The main gas valve shall be wired to close automatically in the event of power failure, flame failure, low water or any safety shutdown condition. A lubricating plug cock shall be provided as a means for a tightness check of the primary shutoff valve. An additional plug cock shall be furnished at entrance to gas train. High and low gas pressure switches shall be provided. A second motorized safety shutoff valve with plugged leakage test connection shall be provided. A vent valve shall be located between the safety shutoff valves. Gas pressure regulator can be offered as an option.
  4. Burner Turndown: Turndown range shall be 4:1 when firing natural gas (consult with Cleaver-Brooks representative regarding high turndown capability based on available gas pressure).
  5. CO on Natural Gas is 50 ppm with excess air at 30%.
- B. Fuel Series 100 - Light Oil-Fired
1. Burner type - The burner shall be mounted at the front of the boiler and shall be a low pressure air atomizing type approved for operation with CS12-48 Commercial No. 2 oil.
  2. Gas Pilot - The gas pilot shall be a premix type with automatic electric ignition. An electronic detector shall monitor the pilot so that the primary oil valve cannot open until pilot flame has been established. The pilot train shall include one manual shut-off valve, solenoid valve, pressure regulator and one (1) plugged leakage test connection (Canada only).
  3. Oil Pump - An oil pump with a capacity of approximately twice the maximum burning rate shall be included. The motor-driven pump set, shipped loose, to be installed in a location favorable to the oil storage tank, shall be provided.
  4. Oil Burner Piping
    - a. Fuel oil piping on the unit shall include oil pressure regulating devices, oil metering controls, low oil pressure switch, two (2) motorized oil valves and pressure gauges, all integrally mounted on the unit.
  5. Low Pressure Air Atomizing: separate air compressor module, shipped loose, with burner mounted low atomizing air pressure switch.
  6. Turndown range shall be 4:1 when firing No. 2 oil.
  7. Excess air is 25% with 10 ppm CO.
- C. Fuel Series 200 - Light Oil or Gas-Fired
1. Burner type - The burner shall be mounted at the front of the boiler and shall be a combination of the low pressure air atomizing type for oil and multi-port type for gas. The burner shall be approved for operation with either CS12-48 Commercial No. 2 oil or natural gas.
  2. Gas Pilot - The gas pilot shall be a premix type with automatic electric ignition. An electronic detector shall monitor the pilot so that the primary fuel valve cannot open until pilot flame has been established. The pilot train shall include one manual shut-off valve, solenoid valve, pressure regulator and one (1) plugged leakage test connection (Canada only).
  3. Oil Burner
    - a. Oil Pump - An oil pump with a capacity of approximately twice the maximum burning rate shall be included. The motor-driven pump set, shipped loose, shall be provided, to be installed in a location favorable to the oil storage tank.

- b. Oil Burner Piping - Fuel oil piping on the unit shall include oil pressure regulating devices, oil metering controls, low oil pressure switch, two (2) motorized oil valves, and pressure gauges all integrally mounted on the unit.
  - c. Low pressure air atomizing - Separate air compressor module, shipped loose with burner-mounted low-atomizing air pressure switch.
  - d. Burner Turndown - Turndown range shall be 4:1 when firing No. 2 oil.
  - e. Excess air is 25% with 10 ppm CO.
4. Gas Burner
- a. Gas Burner Piping - Gas burner piping on all units shall include a primary gas shutoff valve, motor operated with proof of closure switch and plugged leakage test connection. The main gas valve shall be wired to close automatically in the event of power failure, flame failure, low water or any safety shutdown condition. A lubricating plug cock shall be provided as a means for a tightness check of the primary shutoff valve. An additional plug cock shall be furnished at entrance to gas train. High and low gas pressure switches shall be provided. A second motorized safety shutoff valve with plugged leakage test connection shall be provided. A vent valve shall be located between the safety shutoff valves. Gas pressure regulator can be offered as an option.
  - b. Burner Turndown - Turndown range shall be 4:1 when firing natural gas.
  - c. CO on Natural Gas is 50 ppm with excess air at 30%.

### **CBEX 600 to 800 Horsepower 7 PPM**

- A. Fuel Series 700 - Gas-Fired
- 1. Burner type - The burner shall be mounted at the front of the boiler and shall be of high radiant multi-port type gas entry. Burner shall be approved for operation on natural gas fuel.
  - 2. Gas Pilot - The gas pilot shall be a premix type with automatic electric ignition. An electronic detector shall monitor the pilot so that the primary gas valve cannot open until pilot flame has been established. The pilot train shall include one manual shut-off valve, solenoid valve, pressure regulator and one (1) plugged leakage test connection (Canada only).
  - 3. Gas Burner Piping - Gas burner piping on all units shall include a primary gas shutoff valve, motor operated with proof of closure switch and plugged leakage test connection. The main gas valve shall be wired to close automatically in the event of power failure, flame failure, low water or any safety shutdown condition. A lubricating plug cock shall be provided as a means for a tightness check of the primary shutoff valve. An additional plug cock shall be furnished at entrance to gas train. High and low gas pressure switches shall be provided. A second motorized safety shutoff valve with plugged leakage test connection shall be provided. A vent valve shall be located between the safety shutoff valves. Gas pressure regulator can be offered as an option.
  - 4. Burner Turndown: Turndown range shall be 5:1 when firing natural gas (consult with Cleaver-Brooks representative regarding high turndown capability based on available gas pressure).
  - 5. CO on Natural Gas is 50 ppm with excess air at 30%.
- B. Fuel Series 100 - Light Oil-Fired
- 1. Burner type - The burner shall be mounted at the front of the boiler and shall be a low pressure air atomizing type approved for operation with CS12-48 Commercial No. 2 oil.

2. Gas Pilot - The gas pilot shall be a premix type with automatic electric ignition. An electronic detector shall monitor the pilot so that the primary oil valve cannot open until pilot flame has been established. The pilot train shall include one manual shut-off valve, solenoid valve, pressure regulator and one (1) plugged leakage test connection (Canada only).
  3. Oil Pump - An oil pump with a capacity of approximately twice the maximum burning rate shall be included. The motor-driven pump set, shipped loose, to be installed in a location favorable to the oil storage tank, shall be provided.
  4. Oil Burner Piping
    - a. Fuel oil piping on the unit shall include oil pressure regulating devices, oil metering controls, low oil pressure switch, two (2) motorized oil valves and pressure gauges, all integrally mounted on the unit.
  5. Low Pressure Air Atomizing: separate air compressor module, shipped loose, with burner mounted low atomizing air pressure switch.
  6. Turndown range shall be 5:1 when firing No. 2 oil.
  7. Excess air is 25% with 10 ppm CO.
- C. Fuel Series 200 - Light Oil or Gas-Fired
1. Burner type - The burner shall be mounted at the front of the boiler and shall be a combination of the low pressure air atomizing type for oil and multi-port type for gas. The burner shall be approved for operation with either CS12-48 Commercial No. 2 oil or natural gas.
  2. Gas Pilot - The gas pilot shall be a premix type with automatic electric ignition. An electronic detector shall monitor the pilot so that the primary fuel valve cannot open until pilot flame has been established. The pilot train shall include one manual shut-off valve, solenoid valve, pressure regulator and one (1) plugged leakage test connection (Canada only).
  3. Oil Burner
    - a. Oil Pump - An oil pump with a capacity of approximately twice the maximum burning rate shall be included. The motor-driven pump set, shipped loose, shall be provided, to be installed in a location favorable to the oil storage tank.
    - b. Oil Burner Piping - Fuel oil piping on the unit shall include oil pressure regulating devices, oil metering controls, low oil pressure switch, two (2) motorized oil valves, and pressure gauges all integrally mounted on the unit.
    - c. Low pressure air atomizing - Separate air compressor module, shipped loose with burner-mounted low-atomizing air pressure switch.
    - d. Burner Turndown - Turndown range shall be 5:1 when firing No. 2 oil.
    - e. Excess air is 25% with 10 ppm CO.
  4. Gas Burner
    - a. Gas Burner Piping - Gas burner piping on all units shall include a primary gas shutoff valve, motor operated with proof of closure switch and plugged leakage test connection. The main gas valve shall be wired to close automatically in the event of power failure, flame failure, low water or any safety shutdown condition. A lubricating plug cock shall be provided as a means for a tightness check of the primary shutoff valve. An additional plug cock shall be furnished at entrance to gas train. High and low gas pressure switches shall be provided. A second motorized safety shutoff valve with plugged leakage test connection shall be provided. A vent valve shall be located between the safety shutoff valves. Gas pressure regulator can be offered as an option.

- b. Burner Turndown - Turndown range shall be 5:1 when firing natural gas.
- c. CO on Natural Gas is 50 ppm with excess air at 30%.

## 2.5 BOILER CONTROLS AND CONTROL PANEL

- A. Control/Entrance Panel - A common enclosure shall house the control panel and the entrance panel. Enclosure shall be NEMA 4/12 rated and shall be mounted at the side of the boiler in a location convenient to the operator. Enclosure shall consist of upper and lower sections divided by a partition with a separate hinged door for each section. Upper section (low voltage) will house boiler controls including flame safeguard and water level system controller. Lower panel section (high voltage) will house entrance panel.
- B. Cleaver Brooks Combustion Control System - Hawk 2000 with parallel positioning with separate actuators for each fuel and combustion air shall be used to provide proper fuel air ratio control.
- C. CB780E Flame Safeguard - Each boiler shall be factory equipped with flame safeguard controller incorporated into the Hawk control.

Oil, heat and moisture resistant wire shall be used and identified with circuit numbers corresponding to the electrical wiring diagram.

Boiler to be supplied with a control circuit transformer and fuse protection for the control circuit.

## 2.6 FLUE GAS HEAT RECOVERY (OPTIONAL SELECTION)

- A. Add Cleaver Brooks economizer selection in this area.
- B. Boiler and economizer to be designed with integral supports allowing for easy economizer installation on boiler eliminating the requirement for separate structure steel support.

## 2.7 EFFICIENCY GUARANTEE

- A. The boiler must be guaranteed to operate at a minimum fuel-to-steam efficiency of \_\_\_\_\_ percent at 100% of rating when burning natural gas and \_\_\_\_\_ fuel-to-steam efficiency at 100% firing rate when burning oil (Contact your local Cleaver-Brooks authorized representative for efficiency details).

# **PART 3 EXECUTION**

## 3.1 WARRANTY

- A. All equipment is to be guaranteed against defects in materials and/or workmanship for a period of 12 months from date of start-up, or 18 months from date of shipment; whichever comes first.

## 3.2 SHOP TESTS

- A. The packaged boiler must receive factory tests to check the construction, controls, and operation of the unit. All tests may be witnessed by the purchaser, if desired.
- B. Start-up Service
  - 1. After boiler installation is completed, the manufacturer shall provide the services of a field representative for starting the unit and training the operator at no additional costs.
  - 2. A factory-approved and authorized start-up report shall be submitted to the customer/user at the time of start-up.



## Sample Specifications Hot Water

### Model CBEX Elite 100-800 HP

GENERAL

Boiler Characteristics (Hot Water) ----- 50

PRODUCTS

General Boiler Design ----- 50  
 Hot Water Boiler Trim ----- 51  
 Burner ----- 51  
 Fuel Specification And Piping ----- 51  
 60 PPM----- 52  
 30 PPM----- 57  
 9 PPM ----- 62  
 7 PPM ----- 69  
 Boiler Controls And Control Panel ----- 74  
 Flue Gas Heat Recovery (Optional Selection) ----- 74  
 Efficiency Guarantee ----- 74

EXECUTION

Warranty ----- 74  
 Shop Tests ----- 74

### **SAMPLE SPECIFICATIONS**

The following sample specifications are provided by Cleaver-Brooks to assist you in meeting your customer's specific needs and application.

The Sample Specifications are typically utilized as the base template for the complete boiler specification. Contact your local Cleaver-Brooks authorized representative for information on special insurance requirements, special code requirements, optional equipment, or general assistance in completing the specification.

**PART 1 GENERAL****CBEX Hot Water Boiler 100-800 HP**

## 4.1 BOILER CHARACTERISTICS (HOT WATER)

- A. The boiler shall be Cleaver-Brooks Fuel Series \_\_\_\_\_ (100, 200, 700), \_\_\_\_\_ hp designed for \_\_\_\_\_ psig (30, 125, or other) hot water. The maximum operating pressure shall be \_\_\_\_\_ psig and the minimum operating pressure shall be \_\_\_\_\_ psig.
- B. The boiler shall have a maximum output of \_\_\_\_\_ Btu/hr, or \_\_\_\_\_ horsepower when fired with CS12-48 #2 oil and/or natural gas, \_\_\_\_\_ Btu/cu-ft. Electrical power available shall be \_\_\_\_\_ Volt \_\_\_\_\_ Phase \_\_\_\_\_ Cycle.

**PART 2 PRODUCTS**

## 5.1 GENERAL BOILER DESIGN

- A. Design shall be optimized using CFD modeling verifiable by manufacturer. The boiler shall be a multipass pass horizontal firetube updraft boiler with using extended heating surface optimized to reduce boiler foot print. Boiler shall be mounted on a heavy steel frame with integral forced draft burner and burner controls.
1. The boiler shall be completely preassembled and fire tested at the factory. The unit shall be ready for immediate mounting on floor or simple foundation and ready for attachment of water, fuel, electrical, vent, and blowdown connections.
  2. The boiler shall be built to comply with the following insurance and codes (Factory Mutual, XL GAP, ASME, NFPA 8501).
- B. Boiler Shell (Hot Water)
1. The boiler shell must be constructed in accordance with ASME boiler code and must receive authorized boiler inspection prior to shipment. A copy of the inspection report shall be furnished to the purchaser.
  2. The hot water return and outlet connections shall be located on the top center line of the boiler. The boiler shall be designated to rapidly mix the return water with the boiler water. Forced internal circulation shall be used.
  3. A dip tube shall be included as an integral part of the water outlet.
  4. The boiler shall be furnished with a manhole and handholes to facilitate boiler inspection and cleaning. Two lifting lugs must be located on top of the boiler.
  5. The front smokebox doors shall be davited and sealed with superwool insulation and fastened tightly using locking lugs on steel studs.
  6. The rear head shall be fitted with an access plug for rear fireside inspection.
  7. The boiler tubes shall not include turbulators, swirlers, or other add-on appurtenances.
  8. The exhaust gas vent shall be located at the front of the boiler and be capable of supporting 2000 lbs. The boiler vent shall contain a stack thermometer.
  9. Observation ports for the inspection of flame conditions shall be provided at each end of the boiler.
  10. The boiler insulation shall consist of 2 inch blanket under a sectional pre-formed sheet metal lagging. The insulation must be readily removable and capable of being reinstalled if required.
  11. The entire boiler base frame and other components shall be factory painted before shipment, using a hard-finish enamel coating.
  12. The boiler shall contain a chemical feed connection.

## 5.2 HOT WATER BOILER TRIM

- A. Low Water Cutoff - A low water cutoff control (manual reset) shall be mounted on the top centerline of the boiler wired into the burner control circuit to prevent burner operation if boiler water falls below a safe level.
- B. Pressure and Temperature Gauges - Pressure and temperature gauges shall be mounted on the boiler with temperature sensing element located adjacent to the hot water outlet.
- C. Relief Valves - Water relief valves of a type and size to comply with ASME Code requirements shall be shipped loose.
- D. Temperature Controls - Temperature controls to regulate burner operation shall be mounted on the unit with temperature sensing elements located adjacent to the hot water outlet. Controls shall be high limit (manual reset), operating limit (auto reset), and firing rate control.

## 5.3 BURNER

- A. Burner shall incorporate Cleaver Brooks "Lean Burn Technology".
- B. Fuel and air ratio/mixture shall be controlled over the entire operating range, allowing for firing at constant excess air on high turndown burner application.
- C. Burner to be designed specifically for boiler including optimized furnace allowing for low emissions and lean burn combustion.
- D. Mode of Operation
  1. Burner operation shall be full modulation principle. The burner shall always return to low fire position for ignition.
  2. A low fire hold temperature control is mounted and wired on the boiler.
- E. Blower
  1. Air for combustion shall be supplied by a forced draft blower incorporated into the burner design to eliminate vibration and reduce noise level.
  2. Maximum sound level of the boiler/burner package shall not exceed \_\_\_\_\_ dbA (when measured in accordance with ABMA Sound Test Standards).
  3. The impeller shall be fabricated aluminum with radial blade, carefully balanced, and directly connected to the blower motor shaft.
- F. Combustion Air Control  
Combustion air damper and fuel metering valve shall be operated by individual actuators to regulate the flame according to load demand.

## 5.4 FUEL SPECIFICATION AND PIPING

Select one of the following fuel types:

- Fuel series 700 - Gas-fired.
- Fuel series 100 - Light oil (No. 2) fired .
- Fuel series 200 - Light oil or gas-fired.

**NOTE: Specification writer to select between NOx options of 60 ppm, 30 ppm, 9 ppm or 7 ppm Nox on Natural Gas as required for specific project conditions.**

## **60 PPM Nox Operation Natural Gas**

### **CBEX 100 to 200 Horsepower 60 PPM**

- A. Fuel Series 700 - Gas-Fired
1. Burner type - The burner shall be mounted at the front of the boiler and shall be of high radiant multi-port type gas entry. Burner shall be approved for operation on natural gas fuel.
  2. Gas Pilot - The gas pilot shall be a premix type with automatic electric ignition. An electronic detector shall monitor the pilot so that the primary gas valve cannot open until pilot flame has been established. The pilot train shall include one manual shut-off valve, solenoid valve, pressure regulator and one (1) plugged leakage test connection (Canada only).
  3. Gas Burner Piping - Gas burner piping on all units shall include a primary gas shutoff valve, motor operated with proof of closure switch and plugged leakage test connection. The main gas valve shall be wired to close automatically in the event of power failure, flame failure, low water or any safety shutdown condition. A lubricating plug cock shall be provided as a means for a tightness check of the primary shutoff valve. An additional plug cock shall be furnished at entrance to gas train. High and low gas pressure switches shall be provided. A second motorized safety shutoff valve with plugged leakage test connection shall be provided. A vent valve shall be located between the safety shutoff valves. Gas pressure regulator can be offered as an option.
  4. Burner Turndown: Turndown range shall be 4:1 when firing natural gas (consult with Cleaver-Brooks representative regarding high turndown capability based on available gas pressure).
  5. CO on Natural Gas is 10 ppm at 50, 75 and 100 % of firing and 25 ppm at 25% firing rate. Excess air is 15% at 50, 75 and 100% of firing and 30% at 25% firing rate.
- B. Fuel Series 100 - Light Oil-Fired
1. Burner type - The burner shall be mounted at the front of the boiler and shall be a low pressure air atomizing type approved for operation with CS12-48 Commercial No. 2 oil.
  2. Gas Pilot - The gas pilot shall be a premix type with automatic electric ignition. An electronic detector shall monitor the pilot so that the primary oil valve cannot open until pilot flame has been established. The pilot train shall include one manual shut-off valve, solenoid valve, pressure regulator and one (1) plugged leakage test connection (Canada only).
  3. Oil Pump - An oil pump with a capacity of approximately twice the maximum burning rate shall be included. The motor-driven pump set, shipped loose, to be installed in a location favorable to the oil storage tank, shall be provided.
  4. Oil Burner Piping
    - a. Fuel oil piping on the unit shall include oil pressure regulating devices, oil metering controls, low oil pressure switch, two (2) motorized oil valves and pressure gauges, all integrally mounted on the unit.
  5. Low Pressure Air Atomizing: separate air compressor module, shipped loose, with burner mounted low atomizing air pressure switch.

6. Turndown range shall be 4:1 when firing No. 2 oil.
  7. Excess air is 25% with 10 ppm CO.
- C. Fuel Series 200 - Light Oil or Gas-Fired
1. Burner type - The burner shall be mounted at the front of the boiler and shall be a combination of the low pressure air atomizing type for oil and multi-port type for gas. The burner shall be approved for operation with either CS12-48 Commercial No. 2 oil or natural gas.
  2. Gas Pilot - The gas pilot shall be a premix type with automatic electric ignition. An electronic detector shall monitor the pilot so that the primary fuel valve cannot open until pilot flame has been established. The pilot train shall include one manual shut-off valve, solenoid valve, pressure regulator and one (1) plugged leakage test connection (Canada only).
  3. Oil Burner
    - a. Oil Pump - An oil pump with a capacity of approximately twice the maximum burning rate shall be included. The motor-driven pump set, shipped loose, shall be provided, to be installed in a location favorable to the oil storage tank.
    - b. Oil Burner Piping - Fuel oil piping on the unit shall include oil pressure regulating devices, oil metering controls, low oil pressure switch, two (2) motorized oil valves, and pressure gauges all integrally mounted on the unit.
    - c. Low pressure air atomizing - Separate air compressor module, shipped loose with burner-mounted low-atomizing air pressure switch.
    - d. Burner Turndown - Turndown range shall be 4:1 when firing No. 2 oil.
    - e. Excess air is 25% with 10 ppm CO
  4. Gas Burner
    - a. Gas Burner Piping - Gas burner piping on all units shall include a primary gas shutoff valve, motor operated with proof of closure switch and plugged leakage test connection. The main gas valve shall be wired to close automatically in the event of power failure, flame failure, low water or any safety shutdown condition. A lubricating plug cock shall be provided as a means for a tightness check of the primary shutoff valve. An additional plug cock shall be furnished at entrance to gas train. High and low gas pressure switches shall be provided. A second motorized safety shutoff valve with plugged leakage test connection shall be provided. A vent valve shall be located between the safety shutoff valves. Gas pressure regulator can be offered as an option.
    - b. Burner Turndown - Turndown range shall be 4:1 when firing natural gas.
    - c. CO on Natural Gas is 10 ppm at 50, 75 and 100 % of firing and 25 ppm at 25% firing rate. Excess air is 15% at 50, 75 and 100% of firing and 30% at 25% firing rate.

### **CBEX 250 and 300 Horsepower 60 PPM**

- A. Fuel Series 700 - Gas-Fired
1. Burner type - The burner shall be mounted at the front of the boiler and shall be of high radiant multi-port type gas entry. Burner shall be approved for operation on natural gas fuel.

2. Gas Pilot - The gas pilot shall be a premix type with automatic electric ignition. An electronic detector shall monitor the pilot so that the primary gas valve cannot open until pilot flame has been established. The pilot train shall include one manual shut-off valve, solenoid valve, pressure regulator and one (1) plugged leakage test connection (Canada only).
  3. Gas Burner Piping - Gas burner piping on all units shall include a primary gas shutoff valve, motor operated with proof of closure switch and plugged leakage test connection. The main gas valve shall be wired to close automatically in the event of power failure, flame failure, low water or any safety shutdown condition. A lubricating plug cock shall be provided as a means for a tightness check of the primary shutoff valve. An additional plug cock shall be furnished at entrance to gas train. High and low gas pressure switches shall be provided. A second motorized safety shutoff valve with plugged leakage test connection shall be provided. A vent valve shall be located between the safety shutoff valves. Gas pressure regulator can be offered as an option.
  4. Burner Turndown: Turndown range shall be 10:1 when firing natural gas. VSD required to maintain 3% O<sub>2</sub> over turndown range.
  5. CO on Natural Gas is 10 ppm with excess air at 15% in firing range of 50% to 100% increasing to 50 ppm CO at 10:1 turndown.
- B. Fuel Series 100 - Light Oil-Fired
1. Burner type - The burner shall be mounted at the front of the boiler and shall be a low pressure air atomizing type approved for operation with CS12-48 Commercial No. 2 oil.
  2. Gas Pilot - The gas pilot shall be a premix type with automatic electric ignition. An electronic detector shall monitor the pilot so that the primary oil valve cannot open until pilot flame has been established. The pilot train shall include one manual shut-off valve, solenoid valve, pressure regulator and one (1) plugged leakage test connection (Canada only).
  3. Oil Pump - An oil pump with a capacity of approximately twice the maximum burning rate shall be included. The motor-driven pump set, shipped loose, to be installed in a location favorable to the oil storage tank, shall be provided.
  4. Oil Burner Piping
    - a. Fuel oil piping on the unit shall include oil pressure regulating devices, oil metering controls, low oil pressure switch, two (2) motorized oil valves and pressure gauges, all integrally mounted on the unit.
  5. Low Pressure Air Atomizing: separate air compressor module, shipped loose, with burner mounted low atomizing air pressure switch.
  6. Turndown range shall be 7:1 when firing No. 2 oil.
  7. Excess air is 25% with 10 ppm CO.
- C. Fuel Series 200 - Light Oil or Gas-Fired
1. Burner type - The burner shall be mounted at the front of the boiler and shall be a combination of the low pressure air atomizing type for oil and multi-port type for gas. The burner shall be approved for operation with either CS12-48 Commercial No. 2 oil or natural gas.
  2. Gas Pilot - The gas pilot shall be a premix type with automatic electric ignition. An electronic detector shall monitor the pilot so that the primary fuel valve cannot open until pilot flame has been established. The pilot train shall include one manual shut-off valve, solenoid valve, pressure regulator and one (1) plugged leakage test connection (Canada only).

3. Oil Burner
  - a. Oil Pump - An oil pump with a capacity of approximately twice the maximum burning rate shall be included. The motor-driven pump set, shipped loose, shall be provided, to be installed in a location favorable to the oil storage tank.
  - b. Oil Burner Piping - Fuel oil piping on the unit shall include oil pressure regulating devices, oil metering controls, low oil pressure switch, two (2) motorized oil valves, and pressure gauges all integrally mounted on the unit.
  - c. Low pressure air atomizing - Separate air compressor module, shipped loose with burner-mounted low-atomizing air pressure switch.
  - d. Burner Turndown - Turndown range shall be 7:1 when firing No. 2 oil.
  - e. Excess air is 25% with 10 ppm CO.
4. Gas Burner
  - a. Gas Burner Piping - Gas burner piping on all units shall include a primary gas shutoff valve, motor operated with proof of closure switch and plugged leakage test connection. The main gas valve shall be wired to close automatically in the event of power failure, flame failure, low water or any safety shutdown condition. A lubricating plug cock shall be provided as a means for a tightness check of the primary shutoff valve. An additional plug cock shall be furnished at entrance to gas train. High and low gas pressure switches shall be provided. A second motorized safety shutoff valve with plugged leakage test connection shall be provided. A vent valve shall be located between the safety shutoff valves. Gas pressure regulator can be offered as an option.
  - b. Burner Turndown - Turndown range shall be 10:1 with 15% excess air when firing natural gas. VSD required to maintain 3% O<sub>2</sub> over turndown range.
  - c. CO on Natural Gas is 10 ppm at 50% to 100% firing increasing to 50 ppm CO at 10:1 turndown.

### **CBEX 350 to 800 Horsepower 60 PPM**

- A. Fuel Series 700 - Gas-Fired
  1. Burner type - The burner shall be mounted at the front of the boiler and shall be of high radiant multi-port type gas entry. Burner shall be approved for operation on natural gas fuel.
  2. Gas Pilot - The gas pilot shall be a premix type with automatic electric ignition. An electronic detector shall monitor the pilot so that the primary gas valve cannot open until pilot flame has been established. The pilot train shall include one manual shut-off valve, solenoid valve, pressure regulator and one (1) plugged leakage test connection (Canada only).
  3. Gas Burner Piping - Gas burner piping on all units shall include a primary gas shutoff valve, motor operated with proof of closure switch and plugged leakage test connection. The main gas valve shall be wired to close automatically in the event of power failure, flame failure, low water or any safety shutdown condition. A lubricating plug cock shall be provided as a means for a tightness check of the primary shutoff valve. An additional plug cock shall be furnished at entrance to gas train. High and low gas pressure switches shall be provided. A second motorized safety shutoff valve with plugged leakage test connection shall be provided. A vent valve shall be located between the safety shutoff valves. Gas pressure regulator can be offered as an option.
  4. Burner Turndown: Turndown range shall be 10:1 with 15% excess air across the turndown range. VSD required to hold excess air across firing range on natural gas.

5. CO on Natural Gas is 10 ppm with excess air at 15%.
- B. Fuel Series 100 - Light Oil-Fired
1. Burner type - The burner shall be mounted at the front of the boiler and shall be a low pressure air atomizing type approved for operation with CS12-48 Commercial No. 2 oil.
  2. Gas Pilot - The gas pilot shall be a premix type with automatic electric ignition. An electronic detector shall monitor the pilot so that the primary oil valve cannot open until pilot flame has been established. The pilot train shall include one manual shut-off valve, solenoid valve, pressure regulator and one (1) plugged leakage test connection (Canada only).
  3. Oil Pump - An oil pump with a capacity of approximately twice the maximum burning rate shall be included. The motor-driven pump set, shipped loose, to be installed in a location favorable to the oil storage tank, shall be provided.
  4. Oil Burner Piping
    - a. Fuel oil piping on the unit shall include oil pressure regulating devices, oil metering controls, low oil pressure switch, two (2) motorized oil valves and pressure gauges, all integrally mounted on the unit.
  5. Low Pressure Air Atomizing: separate air compressor module, shipped loose, with burner mounted low atomizing air pressure switch.
  6. Turndown range shall be 8:1 when firing No. 2 oil.
  7. Excess air is 25% with 10 ppm CO.
- C. Fuel Series 200 - Light Oil or Gas-Fired
1. Burner type - The burner shall be mounted at the front of the boiler and shall be a combination of the low pressure air atomizing type for oil and multi-port type for gas. The burner shall be approved for operation with either CS12-48 Commercial No. 2 oil or natural gas.
  2. Gas Pilot - The gas pilot shall be a premix type with automatic electric ignition. An electronic detector shall monitor the pilot so that the primary fuel valve cannot open until pilot flame has been established. The pilot train shall include one manual shut-off valve, solenoid valve, pressure regulator and one (1) plugged leakage test connection (Canada only).
  3. Oil Burner
    - a. Oil Pump - An oil pump with a capacity of approximately twice the maximum burning rate shall be included. The motor-driven pump set, shipped loose, shall be provided, to be installed in a location favorable to the oil storage tank.
    - b. Oil Burner Piping - Fuel oil piping on the unit shall include oil pressure regulating devices, oil metering controls, low oil pressure switch, two (2) motorized oil valves, and pressure gauges all integrally mounted on the unit.
    - c. Low pressure air atomizing - Separate air compressor module, shipped loose with burner-mounted low-atomizing air pressure switch.
    - d. Burner Turndown - Turndown range shall be 8:1 when firing No. 2 oil.
    - e. Excess air is 25% with 10 ppm CO.
  4. Gas Burner
    - a. Gas Burner Piping - Gas burner piping on all units shall include a primary gas shutoff valve, motor operated with proof of closure switch and plugged leakage test connection. The main gas valve shall be wired to close automatically in the event of power failure, flame failure, low water or any safety shutdown condition. A lubricating

plug cock shall be provided as a means for a tightness check of the primary shutoff valve. An additional plug cock shall be furnished at entrance to gas train. High and low gas pressure switches shall be provided. A second motorized safety shutoff valve with plugged leakage test connection shall be provided. A vent valve shall be located between the safety shutoff valves. Gas pressure regulator can be offered as an option.

- b. Burner Turndown - Turndown range shall be 10:1 when firing natural gas with 15% excess air over the turndown range. VSD required to maintain excess air over turndown range.
- c. CO on Natural Gas is 10 ppm with excess air at 15%.

## 30 PPM Nox Operation Natural Gas

### CBEX 100 to 200 Horsepower 30 PPM

- A. Fuel Series 700 - Gas-Fired
  1. Burner type - The burner shall be mounted at the front of the boiler and shall be of high radiant multi-port type gas entry. Burner shall be approved for operation on natural gas fuel.
  2. Gas Pilot - The gas pilot shall be a premix type with automatic electric ignition. An electronic detector shall monitor the pilot so that the primary gas valve cannot open until pilot flame has been established. The pilot train shall include one manual shut-off valve, solenoid valve, pressure regulator and one (1) plugged leakage test connection (Canada only).
  3. Gas Burner Piping - Gas burner piping on all units shall include a primary gas shutoff valve, motor operated with proof of closure switch and plugged leakage test connection. The main gas valve shall be wired to close automatically in the event of power failure, flame failure, low water or any safety shutdown condition. A lubricating plug cock shall be provided as a means for a tightness check of the primary shutoff valve. An additional plug cock shall be furnished at entrance to gas train. High and low gas pressure switches shall be provided. A second motorized safety shutoff valve with plugged leakage test connection shall be provided. A vent valve shall be located between the safety shutoff valves. Gas pressure regulator can be offered as an option.
  4. Burner Turndown: Turndown range shall be 4:1 when firing natural gas (consult with Cleaver-Brooks representative regarding high turndown capability based on available gas pressure).
  5. CO on Natural Gas is 25 ppm at 50, 75 and 100 % of firing and 50 ppm at 25% firing rate. Excess air is 15% at 50, 75 and 100% of firing and 30% at 25% firing rate.
- B. Fuel Series 100 - Light Oil-Fired
  1. Burner type - The burner shall be mounted at the front of the boiler and shall be a low pressure air atomizing type approved for operation with CS12-48 Commercial No. 2 oil.
  2. Gas Pilot - The gas pilot shall be a premix type with automatic electric ignition. An electronic detector shall monitor the pilot so that the primary oil valve cannot open until pilot flame has been established. The pilot train shall include one manual shut-off valve, solenoid valve, pressure regulator and one (1) plugged leakage test connection (Canada only).
  3. Oil Pump - An oil pump with a capacity of approximately twice the maximum burning rate shall be included. The motor-driven pump set, shipped loose, to be installed in a location favorable to the oil storage tank, shall be provided.

4. Oil Burner Piping
    - a. Fuel oil piping on the unit shall include oil pressure regulating devices, oil metering controls, low oil pressure switch, two (2) motorized oil valves and pressure gauges, all integrally mounted on the unit.
  5. Low Pressure Air Atomizing: separate air compressor module, shipped loose, with burner mounted low atomizing air pressure switch.
  6. Turndown range shall be 4:1 when firing No. 2 oil.
  7. Excess air is 25% with 10 ppm CO.
- C. Fuel Series 200 - Light Oil or Gas-Fired
1. Burner type - The burner shall be mounted at the front of the boiler and shall be a combination of the low pressure air atomizing type for oil and multi-port type for gas. The burner shall be approved for operation with either CS12-48 Commercial No. 2 oil or natural gas.
  2. Gas Pilot - The gas pilot shall be a premix type with automatic electric ignition. An electronic detector shall monitor the pilot so that the primary fuel valve cannot open until pilot flame has been established. The pilot train shall include one manual shut-off valve, solenoid valve, pressure regulator and one (1) plugged leakage test connection (Canada only).
  3. Oil Burner
    - a. Oil Pump - An oil pump with a capacity of approximately twice the maximum burning rate shall be included. The motor-driven pump set, shipped loose, shall be provided, to be installed in a location favorable to the oil storage tank.
    - b. Oil Burner Piping - Fuel oil piping on the unit shall include oil pressure regulating devices, oil metering controls, low oil pressure switch, two (2) motorized oil valves, and pressure gauges all integrally mounted on the unit.
    - c. Low pressure air atomizing - Separate air compressor module, shipped loose with burner-mounted low-atomizing air pressure switch.
    - d. Burner Turndown - Turndown range shall be 4:1 when firing No. 2 oil.
    - e. Excess air is 25% with 10 ppm CO.
  4. Gas Burner
    - a. Gas Burner Piping - Gas burner piping on all units shall include a primary gas shutoff valve, motor operated with proof of closure switch and plugged leakage test connection. The main gas valve shall be wired to close automatically in the event of power failure, flame failure, low water or any safety shutdown condition. A lubricating plug cock shall be provided as a means for a tightness check of the primary shutoff valve. An additional plug cock shall be furnished at entrance to gas train. High and low gas pressure switches shall be provided. A second motorized safety shutoff valve with plugged leakage test connection shall be provided. A vent valve shall be located between the safety shutoff valves. Gas pressure regulator can be offered as an option.
    - b. Burner Turndown - Turndown range shall be 4:1 when firing natural gas.
    - c. CO on Natural Gas is 25 ppm at 50, 75 and 100 % of firing and 50 ppm at 25% firing rate. Excess air is 15% at 50, 75 and 100% of firing and 30% at 25% firing rate.

### **CBEX 250 and 300 Horsepower 30 PPM**

## A. Fuel Series 700 - Gas-Fired

1. Burner type - The burner shall be mounted at the front of the boiler and shall be of high radiant multi-port type gas entry. Burner shall be approved for operation on natural gas fuel.
2. Gas Pilot - The gas pilot shall be a premix type with automatic electric ignition. An electronic detector shall monitor the pilot so that the primary gas valve cannot open until pilot flame has been established. The pilot train shall include one manual shut-off valve, solenoid valve, pressure regulator and one (1) plugged leakage test connection (Canada only).
3. Gas Burner Piping - Gas burner piping on all units shall include a primary gas shutoff valve, motor operated with proof of closure switch and plugged leakage test connection. The main gas valve shall be wired to close automatically in the event of power failure, flame failure, low water or any safety shutdown condition. A lubricating plug cock shall be provided as a means for a tightness check of the primary shutoff valve. An additional plug cock shall be furnished at entrance to gas train. High and low gas pressure switches shall be provided. A second motorized safety shutoff valve with plugged leakage test connection shall be provided. A vent valve shall be located between the safety shutoff valves. Gas pressure regulator can be offered as an option.
4. Burner Turndown: Turndown range shall be 10:1 when firing natural gas with 15% excess air across the firing range. VSD required to hold 15% excess air across the firing range.
5. CO on Natural Gas is 10 ppm with excess air at 15%, from 50% to 100% firing. CO will increase to 50 ppm at 10:1 turndown.

## B. Fuel Series 100 - Light Oil-Fired

1. Burner type - The burner shall be mounted at the front of the boiler and shall be a low pressure air atomizing type approved for operation with CS12-48 Commercial No. 2 oil.
2. Gas Pilot - The gas pilot shall be a premix type with automatic electric ignition. An electronic detector shall monitor the pilot so that the primary oil valve cannot open until pilot flame has been established. The pilot train shall include one manual shut-off valve, solenoid valve, pressure regulator and one (1) plugged leakage test connection (Canada only).
3. Oil Pump - An oil pump with a capacity of approximately twice the maximum burning rate shall be included. The motor-driven pump set, shipped loose, to be installed in a location favorable to the oil storage tank, shall be provided.
4. Oil Burner Piping
  - a. Fuel oil piping on the unit shall include oil pressure regulating devices, oil metering controls, low oil pressure switch, two (2) motorized oil valves and pressure gauges, all integrally mounted on the unit.
5. Low Pressure Air Atomizing: separate air compressor module, shipped loose, with burner mounted low atomizing air pressure switch.
6. Turndown range shall be 7:1 when firing No. 2 oil.
7. Excess air is 25% with 10 ppm CO.

## C. Fuel Series 200 - Light Oil or Gas-Fired

1. Burner type - The burner shall be mounted at the front of the boiler and shall be a combination of the low pressure air atomizing type for oil and multi-port type for gas. The burner shall be approved for operation with either CS12-48 Commercial No. 2 oil or natural gas.

2. Gas Pilot - The gas pilot shall be a premix type with automatic electric ignition. An electronic detector shall monitor the pilot so that the primary fuel valve cannot open until pilot flame has been established. The pilot train shall include one manual shut-off valve, solenoid valve, pressure regulator and one (1) plugged leakage test connection (Canada only).
3. Oil Burner
  - b. Oil Pump - An oil pump with a capacity of approximately twice the maximum burning rate shall be included. The motor-driven pump set, shipped loose, shall be provided, to be installed in a location favorable to the oil storage tank.
  - c. Oil Burner Piping - Fuel oil piping on the unit shall include oil pressure regulating devices, oil metering controls, low oil pressure switch, two (2) motorized oil valves, and pressure gauges all integrally mounted on the unit.
  - d. Low pressure air atomizing - Separate air compressor module, shipped loose with burner-mounted low-atomizing air pressure switch.
  - e. Burner Turndown - Turndown range shall be 7:1 when firing No. 2 oil.
  - f. Excess air is 25% with 10 ppm CO.
4. Gas Burner
  - a. Gas Burner Piping - Gas burner piping on all units shall include a primary gas shutoff valve, motor operated with proof of closure switch and plugged leakage test connection. The main gas valve shall be wired to close automatically in the event of power failure, flame failure, low water or any safety shutdown condition. A lubricating plug cock shall be provided as a means for a tightness check of the primary shutoff valve. An additional plug cock shall be furnished at entrance to gas train. High and low gas pressure switches shall be provided. A second motorized safety shutoff valve with plugged leakage test connection shall be provided. A vent valve shall be located between the safety shutoff valves. Gas pressure regulator can be offered as an option.
  - b. Burner Turndown - Turndown range shall be 10:1 when firing natural gas with 15% excess air over the turndown range. VSD required to hold excess air over turndown.
  - c. CO on Natural Gas is 10 ppm with excess air at 15% from 50% to 100% firing. CO will increase to 50 ppm at turndown of 10:1.

### **CBEX 350 to 800 Horsepower 30 PPM**

- A. Fuel Series 700 - Gas-Fired
  1. Burner type - The burner shall be mounted at the front of the boiler and shall be of high radiant multi-port type gas entry. Burner shall be approved for operation on natural gas fuel.
  2. Gas Pilot - The gas pilot shall be a premix type with automatic electric ignition. An electronic detector shall monitor the pilot so that the primary gas valve cannot open until pilot flame has been established. The pilot train shall include one manual shut-off valve, solenoid valve, pressure regulator and one (1) plugged leakage test connection (Canada only).

3. Gas Burner Piping - Gas burner piping on all units shall include a primary gas shutoff valve, motor operated with proof of closure switch and plugged leakage test connection. The main gas valve shall be wired to close automatically in the event of power failure, flame failure, low water or any safety shutdown condition. A lubricating plug cock shall be provided as a means for a tightness check of the primary shutoff valve. An additional plug cock shall be furnished at entrance to gas train. High and low gas pressure switches shall be provided. A second motorized safety shutoff valve with plugged leakage test connection shall be provided. A vent valve shall be located between the safety shutoff valves. Gas pressure regulator can be offered as an option.
  4. Burner Turndown: Turndown range shall be 10:1 with 15% excess air across the turndown range. VSD required to hold excess air across firing range on natural gas.
  5. CO on Natural Gas is 10 ppm with excess air at 15%.
- B. Fuel Series 100 - Light Oil-Fired
1. Burner type - The burner shall be mounted at the front of the boiler and shall be a low pressure air atomizing type approved for operation with CS12-48 Commercial No. 2 oil.
  2. Gas Pilot - The gas pilot shall be a premix type with automatic electric ignition. An electronic detector shall monitor the pilot so that the primary oil valve cannot open until pilot flame has been established. The pilot train shall include one manual shut-off valve, solenoid valve, pressure regulator and one (1) plugged leakage test connection (Canada only).
  3. Oil Pump - An oil pump with a capacity of approximately twice the maximum burning rate shall be included. The motor-driven pump set, shipped loose, to be installed in a location favorable to the oil storage tank, shall be provided.
  4. Oil Burner Piping
    - a. Fuel oil piping on the unit shall include oil pressure regulating devices, oil metering controls, low oil pressure switch, two (2) motorized oil valves and pressure gauges, all integrally mounted on the unit.
  5. Low Pressure Air Atomizing: separate air compressor module, shipped loose, with burner mounted low atomizing air pressure switch.
  6. Turndown range shall be 8:1 when firing No. 2 oil.
  7. Excess air is 25% with 10 ppm CO.
- C. Fuel Series 200 - Light Oil or Gas-Fired
1. Burner type - The burner shall be mounted at the front of the boiler and shall be a combination of the low pressure air atomizing type for oil and multi-port type for gas. The burner shall be approved for operation with either CS12-48 Commercial No. 2 oil or natural gas.
  2. Gas Pilot - The gas pilot shall be a premix type with automatic electric ignition. An electronic detector shall monitor the pilot so that the primary fuel valve cannot open until pilot flame has been established. The pilot train shall include one manual shut-off valve, solenoid valve, pressure regulator and one (1) plugged leakage test connection (Canada only).
  3. Oil Burner
    - a. Oil Pump - An oil pump with a capacity of approximately twice the maximum burning rate shall be included. The motor-driven pump set, shipped loose, shall be provided, to be installed in a location favorable to the oil storage tank.

- b. Oil Burner Piping - Fuel oil piping on the unit shall include oil pressure regulating devices, oil metering controls, low oil pressure switch, two (2) motorized oil valves, and pressure gauges all integrally mounted on the unit.
  - c. Low pressure air atomizing - Separate air compressor module, shipped loose with burner-mounted low-atomizing air pressure switch.
  - d. Burner Turndown - Turndown range shall be 8:1 when firing No. 2 oil.
  - e. Excess air is 25% with 10 ppm CO.
4. Gas Burner
- a. Gas Burner Piping - Gas burner piping on all units shall include a primary gas shutoff valve, motor operated with proof of closure switch and plugged leakage test connection. The main gas valve shall be wired to close automatically in the event of power failure, flame failure, low water or any safety shutdown condition. A lubricating plug cock shall be provided as a means for a tightness check of the primary shutoff valve. An additional plug cock shall be furnished at entrance to gas train. High and low gas pressure switches shall be provided. A second motorized safety shutoff valve with plugged leakage test connection shall be provided. A vent valve shall be located between the safety shutoff valves. Gas pressure regulator can be offered as an option.
  - b. Burner Turndown - Turndown range shall be 10:1 with 15% excess air across the turndown range. VSD required to hold excess air across firing range on natural gas.
  - c. CO on Natural Gas is 10 ppm with excess air at 15%.

## 9 PPM Nox Operation Natural Gas

### CBEX 100 to 200 Horsepower 9 PPM

- A. Fuel Series 700 - Gas-Fired
- 1. Burner type - The burner shall be mounted at the front of the boiler and shall be of high radiant multi-port type gas entry. Burner shall be approved for operation on natural gas fuel.
  - 2. Gas Pilot - The gas pilot shall be a premix type with automatic electric ignition. An electronic detector shall monitor the pilot so that the primary gas valve cannot open until pilot flame has been established. The pilot train shall include one manual shut-off valve, solenoid valve, pressure regulator and one (1) plugged leakage test connection (Canada only).
  - 3. Gas Burner Piping - Gas burner piping on all units shall include a primary gas shutoff valve, motor operated with proof of closure switch and plugged leakage test connection. The main gas valve shall be wired to close automatically in the event of power failure, flame failure, low water or any safety shutdown condition. A lubricating plug cock shall be provided as a means for a tightness check of the primary shutoff valve. An additional plug cock shall be furnished at entrance to gas train. High and low gas pressure switches shall be provided. A second motorized safety shutoff valve with plugged leakage test connection shall be provided. A vent valve shall be located between the safety shutoff valves. Gas pressure regulator can be offered as an option.
  - 4. Burner Turndown: Turndown range shall be 4:1 when firing natural gas (consult with Cleaver-Brooks representative regarding high turndown capability based on available gas pressure).
  - 5. CO on Natural Gas is 25 ppm with excess air at 25%.

- B. Fuel Series 100 - Light Oil-Fired
1. Burner type - The burner shall be mounted at the front of the boiler and shall be a low pressure air atomizing type approved for operation with CS12-48 Commercial No. 2 oil.
  2. Gas Pilot - The gas pilot shall be a premix type with automatic electric ignition. An electronic detector shall monitor the pilot so that the primary oil valve cannot open until pilot flame has been established. The pilot train shall include one manual shut-off valve, solenoid valve, pressure regulator and one (1) plugged leakage test connection (Canada only).
  3. Oil Pump - An oil pump with a capacity of approximately twice the maximum burning rate shall be included. The motor-driven pump set, shipped loose, to be installed in a location favorable to the oil storage tank, shall be provided.
  4. Oil Burner Piping
    - a. Fuel oil piping on the unit shall include oil pressure regulating devices, oil metering controls, low oil pressure switch, two (2) motorized oil valves and pressure gauges, all integrally mounted on the unit.
  5. Low Pressure Air Atomizing: separate air compressor module, shipped loose, with burner mounted low atomizing air pressure switch.
  6. Turndown range shall be 4:1 when firing No. 2 oil.
  7. Excess air is 25% with 10 ppm CO.
- C. Fuel Series 200 - Light Oil or Gas-Fired
1. Burner type - The burner shall be mounted at the front of the boiler and shall be a combination of the low pressure air atomizing type for oil and multi-port type for gas. The burner shall be approved for operation with either CS12-48 Commercial No. 2 oil or natural gas.
  2. Gas Pilot - The gas pilot shall be a premix type with automatic electric ignition. An electronic detector shall monitor the pilot so that the primary fuel valve cannot open until pilot flame has been established. The pilot train shall include one manual shut-off valve, solenoid valve, pressure regulator and one (1) plugged leakage test connection (Canada only).
  3. Oil Burner
    - a. Oil Pump - An oil pump with a capacity of approximately twice the maximum burning rate shall be included. The motor-driven pump set, shipped loose, shall be provided, to be installed in a location favorable to the oil storage tank.
    - b. Oil Burner Piping - Fuel oil piping on the unit shall include oil pressure regulating devices, oil metering controls, low oil pressure switch, two (2) motorized oil valves, and pressure gauges all integrally mounted on the unit.
    - c. Low pressure air atomizing - Separate air compressor module, shipped loose with burner-mounted low-atomizing air pressure switch.
    - d. Burner Turndown - Turndown range shall be 4:1 when firing No. 2 oil.
    - e. Excess air is 25% with 10 ppm CO.
  4. Gas Burner
    - a. Gas Burner Piping - Gas burner piping on all units shall include a primary gas shutoff valve, motor operated with proof of closure switch and plugged leakage test connection. The main gas valve shall be wired to close automatically in the event of power failure, flame failure, low water or any safety shutdown condition. A lubricating plug cock shall be provided as a means for a tightness check of the primary shutoff valve. An additional plug cock shall be furnished at entrance to gas train. High and

low gas pressure switches shall be provided. A second motorized safety shutoff valve with plugged leakage test connection shall be provided. A vent valve shall be located between the safety shutoff valves. Gas pressure regulator can be offered as an option.

- b. Burner Turndown - Turndown range shall be 4:1 when firing natural gas.
- c. CO on Natural Gas is 25 ppm with excess air at 25%.

### **CBEX 250 to 400 Horsepower 9 PPM**

#### **A. Fuel Series 700 - Gas-Fired**

- 1. Burner type - The burner shall be mounted at the front of the boiler and shall be of high radiant multi-port type gas entry. Burner shall be approved for operation on natural gas fuel.
- 2. Gas Pilot - The gas pilot shall be a premix type with automatic electric ignition. An electronic detector shall monitor the pilot so that the primary gas valve cannot open until pilot flame has been established. The pilot train shall include one manual shut-off valve, solenoid valve, pressure regulator and one (1) plugged leakage test connection (Canada only).
- 3. Gas Burner Piping - Gas burner piping on all units shall include a primary gas shutoff valve, motor operated with proof of closure switch and plugged leakage test connection. The main gas valve shall be wired to close automatically in the event of power failure, flame failure, low water or any safety shutdown condition. A lubricating plug cock shall be provided as a means for a tightness check of the primary shutoff valve. An additional plug cock shall be furnished at entrance to gas train. High and low gas pressure switches shall be provided. A second motorized safety shutoff valve with plugged leakage test connection shall be provided. A vent valve shall be located between the safety shutoff valves. Gas pressure regulator can be offered as an option.
- 4. Burner Turndown: Turndown range shall be 5:1 when firing natural gas (consult with Cleaver-Brooks representative regarding high turndown capability based on available gas pressure).
- 5. CO on Natural Gas is 25 ppm with excess air at 25%.

#### **B. Fuel Series 100 - Light Oil-Fired**

- 1. Burner type - The burner shall be mounted at the front of the boiler and shall be a low pressure air atomizing type approved for operation with CS12-48 Commercial No. 2 oil.
- 2. Gas Pilot - The gas pilot shall be a premix type with automatic electric ignition. An electronic detector shall monitor the pilot so that the primary oil valve cannot open until pilot flame has been established. The pilot train shall include one manual shut-off valve, solenoid valve, pressure regulator and one (1) plugged leakage test connection (Canada only).
- 3. Oil Pump - An oil pump with a capacity of approximately twice the maximum burning rate shall be included. The motor-driven pump set, shipped loose, to be installed in a location favorable to the oil storage tank, shall be provided.
- 4. Oil Burner Piping
  - a. Fuel oil piping on the unit shall include oil pressure regulating devices, oil metering controls, low oil pressure switch, two (2) motorized oil valves and pressure gauges, all integrally mounted on the unit.
- 5. Low Pressure Air Atomizing: separate air compressor module, shipped loose, with burner mounted low atomizing air pressure switch.

6. Turndown range shall be 5:1 when firing No. 2 oil.
  7. Excess air is 25% with 10 ppm CO.
- C. Fuel Series 200 - Light Oil or Gas-Fired
1. Burner type - The burner shall be mounted at the front of the boiler and shall be a combination of the low pressure air atomizing type for oil and multi-port type for gas. The burner shall be approved for operation with either CS12-48 Commercial No. 2 oil or natural gas.
  2. Gas Pilot - The gas pilot shall be a premix type with automatic electric ignition. An electronic detector shall monitor the pilot so that the primary fuel valve cannot open until pilot flame has been established. The pilot train shall include one manual shut-off valve, solenoid valve, pressure regulator and one (1) plugged leakage test connection (Canada only).
  3. Oil Burner
    - a. Oil Pump - An oil pump with a capacity of approximately twice the maximum burning rate shall be included. The motor-driven pump set, shipped loose, shall be provided, to be installed in a location favorable to the oil storage tank.
    - b. Oil Burner Piping - Fuel oil piping on the unit shall include oil pressure regulating devices, oil metering controls, low oil pressure switch, two (2) motorized oil valves, and pressure gauges all integrally mounted on the unit.
    - c. Low pressure air atomizing - Separate air compressor module, shipped loose with burner-mounted low-atomizing air pressure switch.
    - d. Burner Turndown - Turndown range shall be 5:1 when firing No. 2 oil.
    - e. Excess air is 25% with 10 ppm CO.
  4. Gas Burner
    - a. Gas Burner Piping - Gas burner piping on all units shall include a primary gas shutoff valve, motor operated with proof of closure switch and plugged leakage test connection. The main gas valve shall be wired to close automatically in the event of power failure, flame failure, low water or any safety shutdown condition. A lubricating plug cock shall be provided as a means for a tightness check of the primary shutoff valve. An additional plug cock shall be furnished at entrance to gas train. High and low gas pressure switches shall be provided. A second motorized safety shutoff valve with plugged leakage test connection shall be provided. A vent valve shall be located between the safety shutoff valves. Gas pressure regulator can be offered as an option.
    - b. Burner Turndown - Turndown range shall be 5:1 when firing natural gas.
    - c. CO on Natural Gas is 25 ppm with excess air at 25%.

### **CBEX 500 and 600 Horsepower 9 PPM**

- A. Fuel Series 700 - Gas-Fired
1. Burner type - The burner shall be mounted at the front of the boiler and shall be of high radiant multi-port type gas entry. Burner shall be approved for operation on natural gas fuel.

2. Gas Pilot - The gas pilot shall be a premix type with automatic electric ignition. An electronic detector shall monitor the pilot so that the primary gas valve cannot open until pilot flame has been established. The pilot train shall include one manual shut-off valve, solenoid valve, pressure regulator and one (1) plugged leakage test connection (Canada only).
  3. Gas Burner Piping - Gas burner piping on all units shall include a primary gas shutoff valve, motor operated with proof of closure switch and plugged leakage test connection. The main gas valve shall be wired to close automatically in the event of power failure, flame failure, low water or any safety shutdown condition. A lubricating plug cock shall be provided as a means for a tightness check of the primary shutoff valve. An additional plug cock shall be furnished at entrance to gas train. High and low gas pressure switches shall be provided. A second motorized safety shutoff valve with plugged leakage test connection shall be provided. A vent valve shall be located between the safety shutoff valves. Gas pressure regulator can be offered as an option.
  4. Burner Turndown: Turndown range shall be 6:1 when firing natural gas (consult with Cleaver-Brooks representative regarding high turndown capability based on available gas pressure).
  5. CO on Natural Gas is 25 ppm with excess air at 25%.
- B. Fuel Series 100 - Light Oil-Fired
1. Burner type - The burner shall be mounted at the front of the boiler and shall be a low pressure air atomizing type approved for operation with CS12-48 Commercial No. 2 oil.
  2. Gas Pilot - The gas pilot shall be a premix type with automatic electric ignition. An electronic detector shall monitor the pilot so that the primary oil valve cannot open until pilot flame has been established. The pilot train shall include one manual shut-off valve, solenoid valve, pressure regulator and one (1) plugged leakage test connection (Canada only).
  3. Oil Pump - An oil pump with a capacity of approximately twice the maximum burning rate shall be included. The motor-driven pump set, shipped loose, to be installed in a location favorable to the oil storage tank, shall be provided.
  4. Oil Burner Piping
    - a. Fuel oil piping on the unit shall include oil pressure regulating devices, oil metering controls, low oil pressure switch, two (2) motorized oil valves and pressure gauges, all integrally mounted on the unit.
  5. Low Pressure Air Atomizing: separate air compressor module, shipped loose, with burner mounted low atomizing air pressure switch.
  6. Turndown range shall be 6:1 when firing No. 2 oil.
  7. Excess air is 25% with 10 ppm CO.
- C. Fuel Series 200 - Light Oil or Gas-Fired
1. Burner type - The burner shall be mounted at the front of the boiler and shall be a combination of the low pressure air atomizing type for oil and multi-port type for gas. The burner shall be approved for operation with either CS12-48 Commercial No. 2 oil or natural gas.
  2. Gas Pilot - The gas pilot shall be a premix type with automatic electric ignition. An electronic detector shall monitor the pilot so that the primary fuel valve cannot open until pilot flame has been established. The pilot train shall include one manual shut-off valve, solenoid valve, pressure regulator and one (1) plugged leakage test connection (Canada only).

3. Oil Burner
  - a. Oil Pump - An oil pump with a capacity of approximately twice the maximum burning rate shall be included. The motor-driven pump set, shipped loose, shall be provided, to be installed in a location favorable to the oil storage tank.
  - b. Oil Burner Piping - Fuel oil piping on the unit shall include oil pressure regulating devices, oil metering controls, low oil pressure switch, two (2) motorized oil valves, and pressure gauges all integrally mounted on the unit.
  - c. Low pressure air atomizing - Separate air compressor module, shipped loose with burner-mounted low-atomizing air pressure switch.
  - d. Burner Turndown - Turndown range shall be 6:1 when firing No. 2 oil.
  - e. Excess air is 25% with 10 ppm CO.
4. Gas Burner
  - a. Gas Burner Piping - Gas burner piping on all units shall include a primary gas shutoff valve, motor operated with proof of closure switch and plugged leakage test connection. The main gas valve shall be wired to close automatically in the event of power failure, flame failure, low water or any safety shutdown condition. A lubricating plug cock shall be provided as a means for a tightness check of the primary shutoff valve. An additional plug cock shall be furnished at entrance to gas train. High and low gas pressure switches shall be provided. A second motorized safety shutoff valve with plugged leakage test connection shall be provided. A vent valve shall be located between the safety shutoff valves. Gas pressure regulator can be offered as an option.
  - b. Burner Turndown - Turndown range shall be 6:1 when firing natural gas.
  - c. CO on Natural Gas is 25 ppm with excess air at 25%.

### **CBEX 700 and 800 Horsepower 9 PPM**

- A. Fuel Series 700 - Gas-Fired
  1. Burner type - The burner shall be mounted at the front of the boiler and shall be of high radiant multi-port type gas entry. Burner shall be approved for operation on natural gas fuel.
  2. Gas Pilot - The gas pilot shall be a premix type with automatic electric ignition. An electronic detector shall monitor the pilot so that the primary gas valve cannot open until pilot flame has been established. The pilot train shall include one manual shut-off valve, solenoid valve, pressure regulator and one (1) plugged leakage test connection (Canada only).
  3. Gas Burner Piping - Gas burner piping on all units shall include a primary gas shutoff valve, motor operated with proof of closure switch and plugged leakage test connection. The main gas valve shall be wired to close automatically in the event of power failure, flame failure, low water or any safety shutdown condition. A lubricating plug cock shall be provided as a means for a tightness check of the primary shutoff valve. An additional plug cock shall be furnished at entrance to gas train. High and low gas pressure switches shall be provided. A second motorized safety shutoff valve with plugged leakage test connection shall be provided. A vent valve shall be located between the safety shutoff valves. Gas pressure regulator can be offered as an option.
  4. Burner Turndown: Turndown range shall be 7:1 when firing natural gas (consult with Cleaver-Brooks representative regarding high turndown capability based on available gas pressure).
  5. CO on Natural Gas is 25 ppm with excess air at 25%.

- B. Fuel Series 100 - Light Oil-Fired
1. Burner type - The burner shall be mounted at the front of the boiler and shall be a low pressure air atomizing type approved for operation with CS12-48 Commercial No. 2 oil.
  2. Gas Pilot - The gas pilot shall be a premix type with automatic electric ignition. An electronic detector shall monitor the pilot so that the primary oil valve cannot open until pilot flame has been established. The pilot train shall include one manual shut-off valve, solenoid valve, pressure regulator and one (1) plugged leakage test connection (Canada only).
  3. Oil Pump - An oil pump with a capacity of approximately twice the maximum burning rate shall be included. The motor-driven pump set, shipped loose, to be installed in a location favorable to the oil storage tank, shall be provided.
  4. Oil Burner Piping
    - a. Fuel oil piping on the unit shall include oil pressure regulating devices, oil metering controls, low oil pressure switch, two (2) motorized oil valves and pressure gauges, all integrally mounted on the unit.
  5. Low Pressure Air Atomizing: separate air compressor module, shipped loose, with burner mounted low atomizing air pressure switch.
  6. Turndown range shall be 7:1 when firing No. 2 oil.
  7. Excess air is 25% with 10 ppm CO.
- C. Fuel Series 200 - Light Oil or Gas-Fired
1. Burner type - The burner shall be mounted at the front of the boiler and shall be a combination of the low pressure air atomizing type for oil and multi-port type for gas. The burner shall be approved for operation with either CS12-48 Commercial No. 2 oil or natural gas.
  2. Gas Pilot - The gas pilot shall be a premix type with automatic electric ignition. An electronic detector shall monitor the pilot so that the primary fuel valve cannot open until pilot flame has been established. The pilot train shall include one manual shut-off valve, solenoid valve, pressure regulator and one (1) plugged leakage test connection (Canada only).
  3. Oil Burner
    - a. Oil Pump - An oil pump with a capacity of approximately twice the maximum burning rate shall be included. The motor-driven pump set, shipped loose, shall be provided, to be installed in a location favorable to the oil storage tank.
    - b. Oil Burner Piping - Fuel oil piping on the unit shall include oil pressure regulating devices, oil metering controls, low oil pressure switch, two (2) motorized oil valves, and pressure gauges all integrally mounted on the unit.
    - c. Low pressure air atomizing - Separate air compressor module, shipped loose with burner-mounted low-atomizing air pressure switch.
    - d. Burner Turndown - Turndown range shall be 7:1 when firing No. 2 oil.
    - e. Excess air is 25% with 10 ppm CO.
  4. Gas Burner
    - a. Gas Burner Piping - Gas burner piping on all units shall include a primary gas shutoff valve, motor operated with proof of closure switch and plugged leakage test connection. The main gas valve shall be wired to close automatically in the event of power failure, flame failure, low water or any safety shutdown condition. A lubricating plug cock shall be provided as a means for a tightness check of the primary shutoff valve. An additional plug cock shall be furnished at entrance to gas train. High

and low gas pressure switches shall be provided. A second motorized safety shutoff valve with plugged leakage test connection shall be provided. A vent valve shall be located between the safety shutoff valves. Gas pressure regulator can be offered as an option.

- b. Burner Turndown - Turndown range shall be 7:1 when firing natural gas.
- c. CO on Natural Gas is 25 ppm with excess air at 25%.

## **7 PPM Nox Operation Natural Gas**

### **CBEX 100 to 200 Horsepower 7 PPM**

#### A. Fuel Series 700 - Gas-Fired

- 1. Burner type - The burner shall be mounted at the front of the boiler and shall be of high radiant multi-port type gas entry. Burner shall be approved for operation on natural gas fuel.
- 2. Gas Pilot - The gas pilot shall be a premix type with automatic electric ignition. An electronic detector shall monitor the pilot so that the primary gas valve cannot open until pilot flame has been established. The pilot train shall include one manual shut-off valve, solenoid valve, pressure regulator and one (1) plugged leakage test connection (Canada only).
- 3. Gas Burner Piping - Gas burner piping on all units shall include a primary gas shutoff valve, motor operated with proof of closure switch and plugged leakage test connection. The main gas valve shall be wired to close automatically in the event of power failure, flame failure, low water or any safety shutdown condition. A lubricating plug cock shall be provided as a means for a tightness check of the primary shutoff valve. An additional plug cock shall be furnished at entrance to gas train. High and low gas pressure switches shall be provided. A second motorized safety shutoff valve with plugged leakage test connection shall be provided. A vent valve shall be located between the safety shutoff valves. Gas pressure regulator can be offered as an option.
- 4. Burner Turndown: Turndown range shall be 3:1 when firing natural gas (consult with Cleaver-Brooks representative regarding high turndown capability based on available gas pressure).
- 5. CO on Natural Gas is 50 ppm with excess air at 30%.

#### B. Fuel Series 100 - Light Oil-Fired

- 1. Burner type - The burner shall be mounted at the front of the boiler and shall be a low pressure air atomizing type approved for operation with CS12-48 Commercial No. 2 oil.
- 2. Gas Pilot - The gas pilot shall be a premix type with automatic electric ignition. An electronic detector shall monitor the pilot so that the primary oil valve cannot open until pilot flame has been established. The pilot train shall include one manual shut-off valve, solenoid valve, pressure regulator and one (1) plugged leakage test connection (Canada only).
- 3. Oil Pump - An oil pump with a capacity of approximately twice the maximum burning rate shall be included. The motor-driven pump set, shipped loose, to be installed in a location favorable to the oil storage tank, shall be provided.
- 4. Oil Burner Piping
  - a. Fuel oil piping on the unit shall include oil pressure regulating devices, oil metering controls, low oil pressure switch, two (2) motorized oil valves and pressure gauges, all integrally mounted on the unit.

5. Low Pressure Air Atomizing: separate air compressor module, shipped loose, with burner mounted low atomizing air pressure switch.
  6. Turndown range shall be 3:1 when firing No. 2 oil.
  7. Excess air is 25% with 10 ppm CO.
- C. Fuel Series 200 - Light Oil or Gas-Fired
1. Burner type - The burner shall be mounted at the front of the boiler and shall be a combination of the low pressure air atomizing type for oil and multi-port type for gas. The burner shall be approved for operation with either CS12-48 Commercial No. 2 oil or natural gas.
  2. Gas Pilot - The gas pilot shall be a premix type with automatic electric ignition. An electronic detector shall monitor the pilot so that the primary fuel valve cannot open until pilot flame has been established. The pilot train shall include one manual shut-off valve, solenoid valve, pressure regulator and one (1) plugged leakage test connection (Canada only).
  3. Oil Burner
    - a. Oil Pump - An oil pump with a capacity of approximately twice the maximum burning rate shall be included. The motor-driven pump set, shipped loose, shall be provided, to be installed in a location favorable to the oil storage tank.
    - b. Oil Burner Piping - Fuel oil piping on the unit shall include oil pressure regulating devices, oil metering controls, low oil pressure switch, two (2) motorized oil valves, b. and pressure gauges all integrally mounted on the unit.
    - c. Low pressure air atomizing - Separate air compressor module, shipped loose with burner-mounted low-atomizing air pressure switch.
    - d. Burner Turndown - Turndown range shall be 3:1 when firing No. 2 oil.
    - e. Excess air is 25% with 10 ppm CO.
  4. Gas Burner
    - a. Gas Burner Piping - Gas burner piping on all units shall include a primary gas shutoff valve, motor operated with proof of closure switch and plugged leakage test connection. The main gas valve shall be wired to close automatically in the event of power failure, flame failure, low water or any safety shutdown condition. A lubricating plug cock shall be provided as a means for a tightness check of the primary shutoff valve. An additional plug cock shall be furnished at entrance to gas train. High and low gas pressure switches shall be provided. A second motorized safety shutoff valve with plugged leakage test connection shall be provided. A vent valve shall be located between the safety shutoff valves. Gas pressure regulator can be offered as an option.
    - b. Burner Turndown - Turndown range shall be 3:1 when firing natural gas.
    - c. CO on Natural Gas is 50 ppm with excess air at 30%.

### **CBEX 250 to 500 Horsepower 7 PPM**

- A. Fuel Series 700 - Gas-Fired
1. Burner type - The burner shall be mounted at the front of the boiler and shall be of high radiant multi-port type gas entry. Burner shall be approved for operation on natural gas fuel.

2. Gas Pilot - The gas pilot shall be a premix type with automatic electric ignition. An electronic detector shall monitor the pilot so that the primary gas valve cannot open until pilot flame has been established. The pilot train shall include one manual shut-off valve, solenoid valve, pressure regulator and one (1) plugged leakage test connection (Canada only).
  3. Gas Burner Piping - Gas burner piping on all units shall include a primary gas shutoff valve, motor operated with proof of closure switch and plugged leakage test connection. The main gas valve shall be wired to close automatically in the event of power failure, flame failure, low water or any safety shutdown condition. A lubricating plug cock shall be provided as a means for a tightness check of the primary shutoff valve. An additional plug cock shall be furnished at entrance to gas train. High and low gas pressure switches shall be provided. A second motorized safety shutoff valve with plugged leakage test connection shall be provided. A vent valve shall be located between the safety shutoff valves. Gas pressure regulator can be offered as an option.
  4. Burner Turndown: Turndown range shall be 4:1 when firing natural gas (consult with Cleaver-Brooks representative regarding high turndown capability based on available gas pressure).
  5. CO on Natural Gas is 50 ppm with excess air at 30%.
- B. Fuel Series 100 - Light Oil-Fired
1. Burner type - The burner shall be mounted at the front of the boiler and shall be a low pressure air atomizing type approved for operation with CS12-48 Commercial No. 2 oil.
  2. Gas Pilot - The gas pilot shall be a premix type with automatic electric ignition. An electronic detector shall monitor the pilot so that the primary oil valve cannot open until pilot flame has been established. The pilot train shall include one manual shut-off valve, solenoid valve, pressure regulator and one (1) plugged leakage test connection (Canada only).
  3. Oil Pump - An oil pump with a capacity of approximately twice the maximum burning rate shall be included. The motor-driven pump set, shipped loose, to be installed in a location favorable to the oil storage tank, shall be provided.
  4. Oil Burner Piping
    - a. Fuel oil piping on the unit shall include oil pressure regulating devices, oil metering controls, low oil pressure switch, two (2) motorized oil valves and pressure gauges, all integrally mounted on the unit.
  5. Low Pressure Air Atomizing: separate air compressor module, shipped loose, with burner mounted low atomizing air pressure switch.
  6. Turndown range shall be 4:1 when firing No. 2 oil.
  7. Excess air is 25% with 10 ppm CO.
- C. Fuel Series 200 - Light Oil or Gas-Fired
1. Burner type - The burner shall be mounted at the front of the boiler and shall be a combination of the low pressure air atomizing type for oil and multi-port type for gas. The burner shall be approved for operation with either CS12-48 Commercial No. 2 oil or natural gas.
  2. Gas Pilot - The gas pilot shall be a premix type with automatic electric ignition. An electronic detector shall monitor the pilot so that the primary fuel valve cannot open until pilot flame has been established. The pilot train shall include one manual shut-off valve, solenoid valve, pressure regulator and one (1) plugged leakage test connection (Canada only).

3. Oil Burner
  - a. Oil Pump - An oil pump with a capacity of approximately twice the maximum burning rate shall be included. The motor-driven pump set, shipped loose, shall be provided, to be installed in a location favorable to the oil storage tank.
  - b. Oil Burner Piping - Fuel oil piping on the unit shall include oil pressure regulating devices, oil metering controls, low oil pressure switch, two (2) motorized oil valves, and pressure gauges all integrally mounted on the unit.
  - c. Low pressure air atomizing - Separate air compressor module, shipped loose with burner-mounted low-atomizing air pressure switch.
  - d. Burner Turndown - Turndown range shall be 4:1 when firing No. 2 oil.
  - e. Excess air is 25% with 10 ppm CO.
4. Gas Burner
  - a. Gas Burner Piping - Gas burner piping on all units shall include a primary gas shutoff valve, motor operated with proof of closure switch and plugged leakage test connection. The main gas valve shall be wired to close automatically in the event of power failure, flame failure, low water or any safety shutdown condition. A lubricating plug cock shall be provided as a means for a tightness check of the primary shutoff valve. An additional plug cock shall be furnished at entrance to gas train. High and low gas pressure switches shall be provided. A second motorized safety shutoff valve with plugged leakage test connection shall be provided. A vent valve shall be located between the safety shutoff valves. Gas pressure regulator can be offered as an option.
  - b. Burner Turndown - Turndown range shall be 4:1 when firing natural gas.
  - c. CO on Natural Gas is 50 ppm with excess air at 30%.

### **CBEX 600 to 800 Horsepower 7 PPM**

- A. Fuel Series 700 - Gas-Fired
  1. Burner type - The burner shall be mounted at the front of the boiler and shall be of high radiant multi-port type gas entry. Burner shall be approved for operation on natural gas fuel.
  2. Gas Pilot - The gas pilot shall be a premix type with automatic electric ignition. An electronic detector shall monitor the pilot so that the primary gas valve cannot open until pilot flame has been established. The pilot train shall include one manual shut-off valve, solenoid valve, pressure regulator and one (1) plugged leakage test connection (Canada only).
  3. Gas Burner Piping - Gas burner piping on all units shall include a primary gas shutoff valve, motor operated with proof of closure switch and plugged leakage test connection. The main gas valve shall be wired to close automatically in the event of power failure, flame failure, low water or any safety shutdown condition. A lubricating plug cock shall be provided as a means for a tightness check of the primary shutoff valve. An additional plug cock shall be furnished at entrance to gas train. High and low gas pressure switches shall be provided. A second motorized safety shutoff valve with plugged leakage test connection shall be provided. A vent valve shall be located between the safety shutoff valves. Gas pressure regulator can be offered as an option.
  4. Burner Turndown: Turndown range shall be 5:1 when firing natural gas (consult with Cleaver-Brooks representative regarding high turndown capability based on available gas pressure).

5. CO on Natural Gas is 50 ppm with excess air at 30%.
- B. Fuel Series 100 - Light Oil-Fired
  1. Burner type - The burner shall be mounted at the front of the boiler and shall be a low pressure air atomizing type approved for operation with CS12-48 Commercial No. 2 oil.
  2. Gas Pilot - The gas pilot shall be a premix type with automatic electric ignition. An electronic detector shall monitor the pilot so that the primary oil valve cannot open until pilot flame has been established. The pilot train shall include one manual shut-off valve, solenoid valve, pressure regulator and one (1) plugged leakage test connection (Canada only).
  3. Oil Pump - An oil pump with a capacity of approximately twice the maximum burning rate shall be included. The motor-driven pump set, shipped loose, to be installed in a location favorable to the oil storage tank, shall be provided.
  4. Oil Burner Piping
    - a. Fuel oil piping on the unit shall include oil pressure regulating devices, oil metering controls, low oil pressure switch, two (2) motorized oil valves and pressure gauges, all integrally mounted on the unit.
  5. Low Pressure Air Atomizing: separate air compressor module, shipped loose, with burner mounted low atomizing air pressure switch.
  6. Turndown range shall be 5:1 when firing No. 2 oil.
  7. Excess air is 25% with 10 ppm CO.
- C. Fuel Series 200 - Light Oil or Gas-Fired
  1. Burner type - The burner shall be mounted at the front of the boiler and shall be a combination of the low pressure air atomizing type for oil and multi-port type for gas. The burner shall be approved for operation with either CS12-48 Commercial No. 2 oil or natural gas.
  2. Gas Pilot - The gas pilot shall be a premix type with automatic electric ignition. An electronic detector shall monitor the pilot so that the primary fuel valve cannot open until pilot flame has been established. The pilot train shall include one manual shut-off valve, solenoid valve, pressure regulator and one (1) plugged leakage test connection (Canada only).
  3. Oil Burner
    - a. Oil Pump - An oil pump with a capacity of approximately twice the maximum burning rate shall be included. The motor-driven pump set, shipped loose, shall be provided, to be installed in a location favorable to the oil storage tank.
    - b. Oil Burner Piping - Fuel oil piping on the unit shall include oil pressure regulating devices, oil metering controls, low oil pressure switch, two (2) motorized oil valves, and pressure gauges all integrally mounted on the unit.
    - c. Low pressure air atomizing - Separate air compressor module, shipped loose with burner-mounted low-atomizing air pressure switch.
    - d. Burner Turndown - Turndown range shall be 5:1 when firing No. 2 oil.
    - e. Excess air is 25% with 10 ppm CO.
  4. Gas Burner
    - a. Gas Burner Piping - Gas burner piping on all units shall include a primary gas shutoff valve, motor operated with proof of closure switch and plugged leakage test connection. The main gas valve shall be wired to close automatically in the event of power failure, flame failure, low water or any safety shutdown condition. A lubricating

plug cock shall be provided as a means for a tightness check of the primary shutoff valve. An additional plug cock shall be furnished at entrance to gas train. High and low gas pressure switches shall be provided. A second motorized safety shutoff valve with plugged leakage test connection shall be provided. A vent valve shall be located between the safety shutoff valves. Gas pressure regulator can be offered as an option.

- b. Burner Turndown - Turndown range shall be 5:1 when firing natural gas.
- c. CO on Natural Gas is 50 ppm with excess air at 30%.

#### 5.5 BOILER CONTROLS AND CONTROL PANEL

- A. Control/Entrance Panel - A common enclosure shall house the control panel and the entrance panel. Enclosure shall be NEMA 4/12 rated and shall be mounted at the side of the boiler in a location convenient to the operator. Enclosure shall consist of upper and lower sections divided by a partition with a separate hinged door for each section. Upper section (low voltage) will house boiler controls including flame safeguard and water level system controller. Lower panel section (high voltage) will house entrance panel.
- B. Cleaver Brooks Combustion Control System - Hawk 2000 with parallel positioning with separate actuators for each fuel and combustion air shall be used to provide proper fuel air ratio control.
- C. CB780E Flame Safeguard - Each boiler shall be factory equipped with flame safeguard controller incorporated into the Hawk control.

Oil, heat and moisture resistant wire shall be used and identified with circuit numbers corresponding to the electrical wiring diagram.

Boiler to be supplied with a control circuit transformer and fuse protection for the control circuit.

#### 5.6 FLUE GAS HEAT RECOVERY (OPTIONAL SELECTION)

- A. Add Cleaver Brooks economizer selection in this area.
- B. Boiler and economizer to be designed with integral supports allowing for easy economizer installation on boiler eliminating the requirement for separate structure steel support.

#### 5.7 EFFICIENCY GUARANTEE

- A. The boiler must be guaranteed to operate at a minimum fuel-to-water efficiency of \_\_\_\_\_ percent at 100% of rating when burning natural gas and \_\_\_\_\_ fuel-to-water efficiency at 100% firing rate when burning oil (Contact your local Cleaver-Brooks authorized representative for efficiency details).

### **PART 3 EXECUTION**

#### 6.1 WARRANTY

- A. All equipment is to be guaranteed against defects in materials and/or workmanship for a period of 12 months from date of start-up, or 18 months from date of shipment; whichever comes first.

#### 6.2 SHOP TESTS

- A. The packaged boiler must receive factory tests to check the construction, controls, and operation of the unit. All tests may be witnessed by the purchaser, if desired.
- B. Start-up Service
  - 1. After boiler installation is completed, the manufacturer shall provide the services of a field representative for starting the unit and training the operator at no additional costs.
  - 2. A factory-approved and authorized start-up report shall be submitted to the customer/user at the time of start-up.